

Chapter 2 Product Information

2.1 Naming Rules

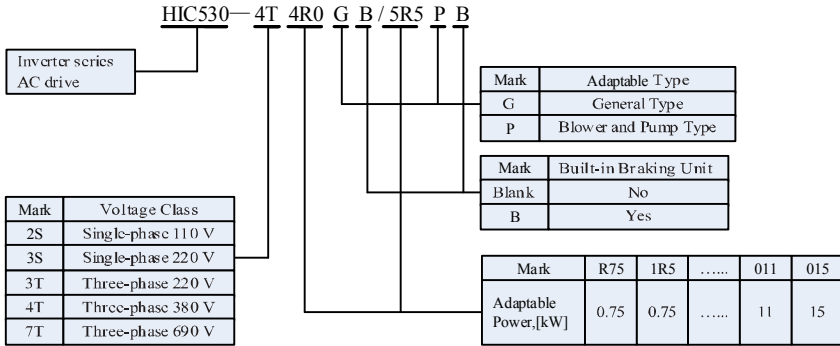

Fig.2-1 Naming Rules

2.2 Nameplate

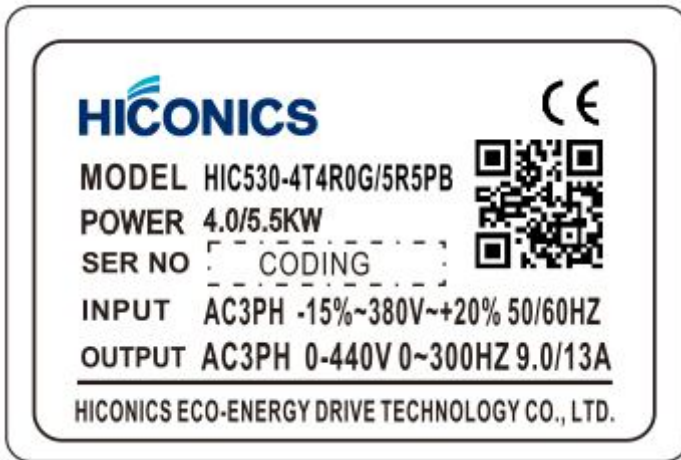

Fig.2-2 Nameplate

2.3 HIC530 Inverter Series

Tab.2-1 models and technical data of HIC530

Model	Input voltage	Input current (A)ND/HD	Output current (A) ND/HD	Matched motor (Kw) ND/HD
HIC530-3SR4G	Single phase 220V Range: -15%~20%	5.4	2.3	0.4
HIC530-3SR75G		8.2	4.0	0.75
HIC530-3S1R5G		14.0	7.0	1.5
HIC530-3S2R2GB		23.0	9.6	2.2
HIC530-3S4R0GB		32.0	17	4.0
HIC530-3S5R5GB		45.0	25	5.5
HIC530-4TR75GB	Three phase 380V Range: -15%~20%	3.4	2.1	0.75
HIC530-4T1R5GB/2R2PB		5.0/5.8	3.8/5.1	1.5/2.2
HIC530-4T2R2GB/4R0PB		5.8/10.5	5.1/9.0	2.2/4.0
HIC530-4T4R0GB/5R5PB		10.5/14.6	9.0/13.0	4.0/5.5
HIC530-4T5R5GB/7R5PB		14.6/20.5	13.0/17.0	5.5/7.5
HIC530-4T7R5GB/9R0PB		20.5/22.0	17.0/20.0	7.5/9.0
HIC530-4T9R0GB/011PB		22.0/26.0	20.0/25.0	9.0/11.0
HIC530-4T011GB/015PB		26.0/35.0	25.0/32.0	11.0/15.0
HIC530-4T015GB/018PB		35.0/38.5	32.0/37.0	15.0/18.5
HIC530-4T018GB/022PB		38.5/46.5	37.0/45.0	18.5/22.0
HIC530-4T022GB/030P(B)		46.5/62.0	45.0/60.0	22.0/30.0
HIC530-4T030G(B)/037P(B)		62.0/76.0	60.0/75.0	30.0/37.0
HIC530-4T037G(B)/045P(B)		76.0/92.0	75.0/90.0	37.0/45.0
HIC530-4T045G(B)/055P(B)		92.0/113.0	90.0/110.0	45.0/55.0
HIC530-4T055G(B)/075P(B)		113.0/157.0	110.0/152.0	55.0/75.0
HIC530-4T075G(B)/093P(B)		157.0/180.0	152.0/176.0	75.0/93.0
HIC530-4T093G(B)/110P		180.0/214.0	176.0/210.0	93.0/110.0
HIC530-4T110G/132P		214.0/256.0	210.0/253.0	110.0/132.0
HIC530-4T132G/160P		256.0/307.0	253.0/304.0	132.0/160.0
HIC530-4T160G/185P		307.0/345.0	304.0/340.0	160.0/185.0
HIC530-4T185G/200P		345.0/385.0	340.0/380.0	185.0/200.0
HIC530-4T200G/220P		385.0/430.0	380.0/426.0	200.0/220.0

Model	Input voltage	Input current (A)ND/HD	Output current (A) ND/HD	Matched motor (Kw) ND/HD
HIC530-4T220G/250P		430.0/468.0	426.0/465.0	220.0/250.0
HIC530-4T250G/280P		468.0/525.0	465.0/520.0	250.0/280.0
HIC530-4T280G/315P		525.0/590.0	520.0/585.0	280.0/315.0
HIC530-4T315G/355P		590.0/665.0	585.0/650.0	315.0/355.0
HIC530-4T355G/400P		665.0/785.0	650.0/725.0	355.0/400.0
HIC530-4T400G/450P		785.0/883.0	725.0/820.0	400.0/450.0
HIC530-4T450G/500P		883.0/920.0	820.0/900.0	450.0/500.0
HIC530-4T500G/550P		920.0/1020.0	900.0/1000.0	500.0/550.0
HIC530-4T550G/630P		1020.0/1120.0	1000.0/1100.0	550.0/630.0
HIC530-4T630G		1120.0	1100.0	630.0
HIC530-4T710G		1315.0	1250	710.0
HIC530-4T800G		1525.0	1450	800.0
HIC530-7T011GB	660-690v	15.6	15.0	11.0
HIC530-7T015GB	660-690v	21.0	20.0	15.0
HIC530-7T030G(B)	660-690v	40.0	38.0	30.0
HIC530-7T037G(B)	660-690v	49.5	47.0	37.0
HIC530-7T045G(B)	660-690v	58	55.0	45.0
HIC530-7T055G(B)	660-690v	70.0	65.0	55.0
HIC530-7T075G(B)	660-690v	90.0	86.0	75.0
HIC530-7T093G(B)	660-690v	105.0	100.0	93.0
HIC530-7T110G	660-690v	130.0	120.0	110.0
HIC530-7T132G	660-690v	170.0	150.0	132.0
HIC530-7T160G	660-690v	200.0	175.0	160.0
HIC530-7T185G	660-690v	208.0	198.0	185.0
HIC530-7T200G	660-690v	235.0	215.0	200.0
HIC530-7T220G	660-690v	247.0	245.0	220.0
HIC530-7T250G	660-690v	265.0	260.0	250.0
HIC530-7T280G	660-690v	305.0	299.0	280.0
HIC530-7T315G	660-690v	350.0	330.0	315.0
HIC530-7T355G	660-690v	382.0	374.0	355.0
HIC530-7T400G	660-690v	435.0	410.0	400.0

Model	Input voltage	Input current (A)ND/HD	Output current (A) ND/HD	Matched motor (Kw) ND/HD
HIC530-7T500G	660-690v	595.0	550.0	500.0
HIC530-7T630G	660-690v	684.0	650.0	630.0
HIC530-7T710G	660-690v	768.5	730.0	710.0

2.4 Technical Specification

Item		Specifications
Main control functions	Maximum frequency	Vector control: 0~600Hz VF control:0~1200Hz
	Carrier Frequency	1k ~ 15kHz; the carrier frequency will be automatically adjusted according to the load characteristics.
	Input frequency resolution	Digital setting: 0.01Hz Analog setting: maximum frequency ×0.1%
	Control mode	Open loop vector control ; V/F control.
	Start-up torque	Mode G machine: 0.5Hz/180% (open loop vector control) Mode P machine: 0.5Hz/120% (Open loop vector control)
	Speed adjustment range	1: 200 (Open loop Vector flux control)
Main control functions	Stable speed Precision	Open loop Vector flux control: $\leq \pm 0.5\%$ (rated synchronous speed)
	Stabilization of speed control	Open loop Vector flux control: $\leq \pm 0.3\%$ (rated synchronous speed)
	Torque response	$\leq 40\text{ms}$ (Open magnetic flux vector control)
	Overload capacity	Mode G machine: 150% rated current 60s; 180% rated current 5s Mode P machine: 130% rated current 60s; 150% rated current 5s
	Torque boost	Automatic torque boost; manual torque boost 0.1% to 30.0%
	V/F curve	Linear V/F, Multi-point V/F, and Square V/F
	Speed-up and Speed-down curve	Straight line or S curve speed-up and speed-down mode; four kinds of speed-up and speed-down time; Speed-up and speed-down time ranges from 0.0s to 3000.0s

Item		Specifications
	DC brake	DC brake frequency: 0.00Hz ~ maximum frequency; brake time: 0.0s ~ 36.0s, and brake current value: 0.0% to 100.0%.
	Jog control	Jog frequency range:0.00Hz ~ 50.00Hz; Jog speed-up/speed-down time: 0.0s ~ 3000.0s.
	Simple PLC and multi-speed running	It can realize a maximum of 16 segments speed running via the built-in PLC or control terminal.
	Built-in PID	It is easy to realize process-controlled close loop control system.
	(AVR) Automatic voltage regulation	It can keep constant output voltage automatically in case of change of mains voltage.
	Torque limit and control	"Shovel" characteristics, automatic limit on the torque on running time, preventing frequent over-current trip; closed loop vector mode can realize the torque control
Customized functions	Peripherals self-detection upon power-on	It can conduct safety detections on the peripherals upon power-on, including earth and short circuit detections.
	Shared DC bus function	It can realize the function that multiple inverters share the DC bus.
	JOG key	Programmable key: Select the forward and reverse rotations/jog operation command.
Customized functions	Traverse frequency control	Multiple triangular-wave frequency control function.
	Fast current limit function	With fast current limit algorithm built in to reduce the probability of over-current alarm; to improve the anti-jamming capacity of the whole machine.
	Timed control	Timing control function: Setting time range from 0h to 65535h.
	Keyboard extension line standardization	Customers can use standard cable to extend the keyboard
Operation function	Running command channel	Three types of channels: operation panel given, control terminal given and serial communication port given. These channels can be switched in various ways.
	Frequency source	Ten types of frequency sources in total: digital given, analog voltage given, analog current given, pulse given, and serial port given. It can be switched in various ways.
	Auxiliary frequency source	Ten types of auxiliary frequency sources in total. It can implement micro tuning and synthesis of auxiliary frequency.

Item		Specifications
	Input terminal	Seven digital input terminals, and nine terminals in maximum (AI1, AI2 can be used as DI terminals), it has compatibility to PNP or NPN input method. Two analog input terminals, in which AI1 only be used for voltage input, and AI2 can be used as voltage or current input. (if expanded- input or output terminal function is needed, please use HIC580 series.)
	Output terminal	One digital output terminal (bipolar output) Two relay output terminal Two analog output terminals, with optional 0/4mA to 20mA or 0/2V to 10V. It can realize the output of set frequency, output frequency and rotation speed etc.
Display and Keyboard Operate	LED display	Display parameter
	LCD display	Selective parts, Chinese/English to suggest the operation content
	LCD Parameter copy	Use LCD parameter special copy keyboard can copy the parameter quickly
	Key lock and function choose	Lock part of the keyboard or the whole keyboard, definite the function range of some keys to avoid mis-operation.
Protection and select accessories	protection function	Short circuit detective of power-on motor, input and output open-phase protection, over-current protection, overvoltage protection, under-voltage protection, over-heat protection, over-load protection etc.
	Selective accessories	LCD operation panel, brake group etc.
Environment	Suitable place	Indoor environment which is against from direct sunlight, dust, corrosive gas, combustible gas, oil mist, vapor, water drop and salt.
	Altitude	Less than 1000m
	Ambient Temperature	-10℃ ~ +50℃ (derating is required if the natural temperature range is 40℃ ~ 50℃)
	Humidity	Less than 95%RH, no condensing water drops
	Vibration	Less than 5.9m/ s ² (0.6g)
	Storage temperature	-20℃ ~ +60℃
	Class of pollution	2

Item		Specifications
Product standard	Safety standard	IEC61800-5-1:2007
	EMC standard	IEC61800-3:2005

2.5 Physical Appearance and Dimensions of Mounting Hole

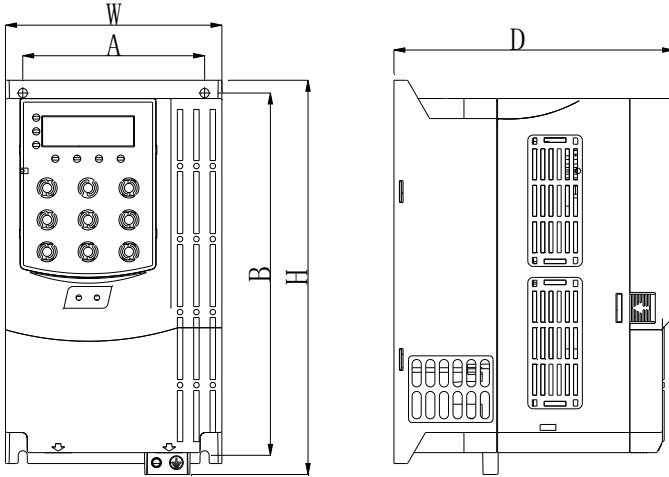

Fig.2-3 Installation dimensions of plastic mode below 7.5 KW

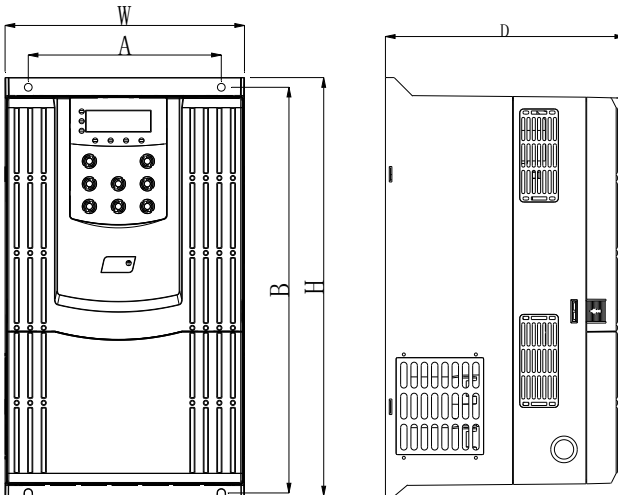

Fig.2-4 Installation dimensions of metal mode within 11~15KW(380V)

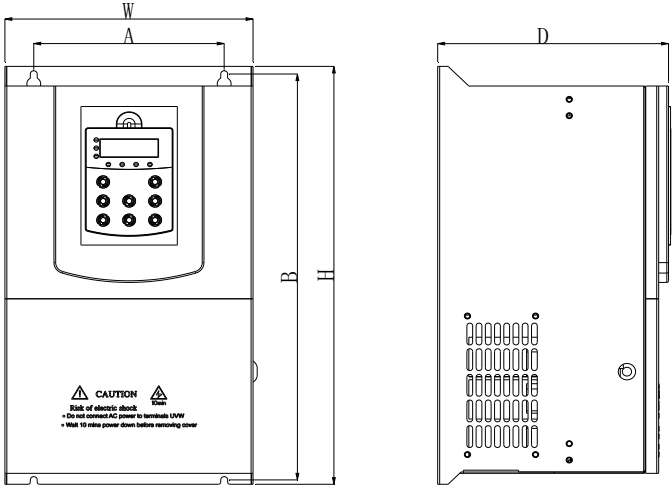

Fig.2-5 Installation dimensions of metal mode within 22~37KW(380V)
Installation dimensions of metal mode within 11~15KW(660V)

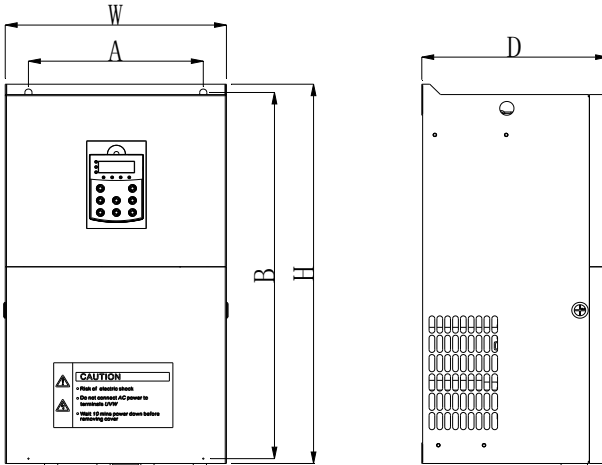

Fig.2-6 Appearance and install dimension of inverter within 45KW~132KW(380V)
Appearance and install dimension of inverter within 30KW~55KW(660V)

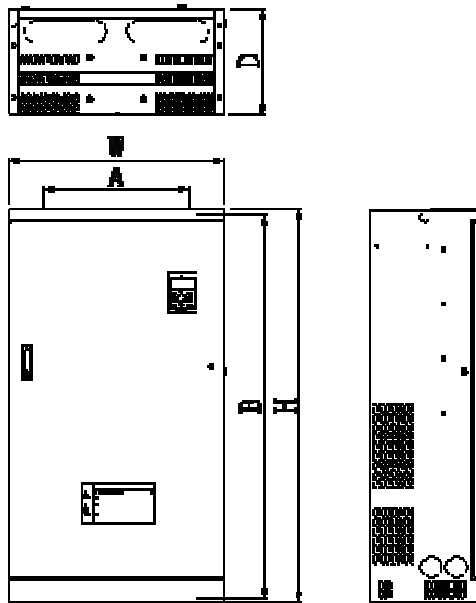

Fig.2-7 Installation dimensions of metal mode above 160KW (380V)

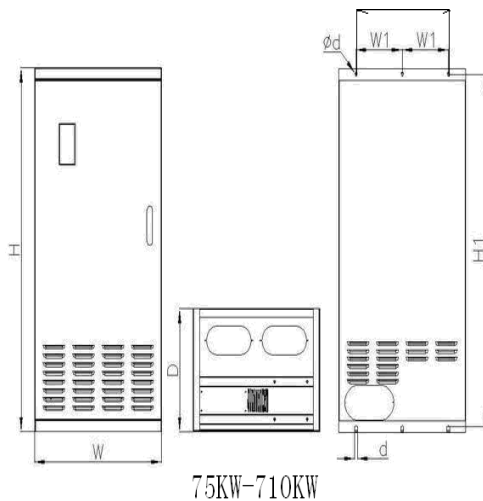
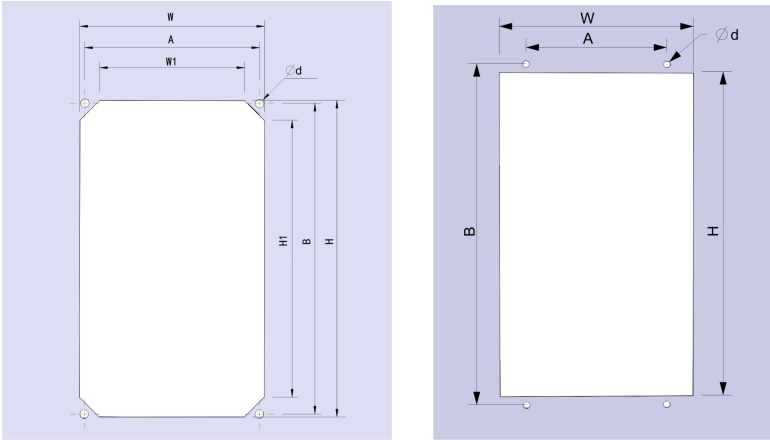

Fig.2-8 Installation dimensions of metal mode above 75KW (660V)

Tab.2-3 mounting hole dimensions of HIC530

Model	Mounting hole		Wall-mounted hole dimension			Diameter of mounting hole (mm)
	A (mm)	B (mm)	H (mm)	W(mm)	D (mm)	
HIC530-3SR4G	78	162	172.5	96	141	φ 4.5
HIC530-3SR75G						
HIC530-3S1R5G						
HIC530-3S2R2GB	100	199	206	119	154	φ 5
HIC530-3S4R0GB	120	260	268	139	155.5	φ 6
HIC530-3S5R5GB						
HIC530-4TR75GB	76(上)	162	172.5	96	141	φ 4.5
HIC530-4T1R5GB/2R2PB	80(下)					
HIC530-4T2R2GB/4R0PB	100	199	206	119	154	φ 5
HIC530-4T4R0GB/5R5PB						
HIC530-4T5R5GB/7R5PB	120	260	268	139	155.5	φ 6
HIC530-4T7R5GB/9R0PB						
HIC530-4T9R0GB/011PB	150	314	324	188	188	φ 6
HIC530-4T011GB/015PB						
HIC530-4T015GB/018PB						
HIC530-4T018GB/022PB	165	372	383	215	200	φ 6
HIC530-4T022GB/030P(B)						
HIC530-4T030G(B)/037P(B)	200	436	449	260	209	φ 7
HIC530-4T037G(B)/045P(B)						
HIC530-4T045G(B)/055P(B)	245	531	550	310	260	φ 10
HIC530-4T055G(B)/075P(B)						
HIC530-4T075G(B)/093P(B)	280	561	580	350	267	φ 10
HIC530-4T093G(B)/110P						
HIC530-4T110G/132P	320	695	715	430	295	φ 10
HIC530-4T132G/160P						
HIC530-4T160G/185P	360	972	1000	470	318	φ 12
HIC530-4T185G/200P						
HIC530-4T200G/220P	380	1060	1088	520	338	φ 12
HIC530-4T220G/250P						
HIC530-4T250G/280P	440	1190	1220	650	330	φ 12
HIC530-4T280G/315P						
HIC530-4T315G/355P	500	1255	1290	740	420	φ 14
HIC530-4T355G/400P						
HIC530-4T400G/450P						

Model	Mounting hole		Wall-mounted hole dimension			Diameter of mounting hole (mm)
	A (mm)	B (mm)	H (mm)	W(mm)	D (mm)	
HIC530-4T450G/500P	-	-	1800	1060	500	- (立式)
HIC530-4T500G/550P						
HIC530-4T550G/630P						
HIC530-4T630G						
HIC530-4T710G	-	-	2200	1200	600	- (立式)
HIC530-4T800G						
HIC530-7T011GB	165	372	383	215	200	φ 6
HIC530-7T015GB						
HIC530-7T030G(B)	590	220	610	310	300	φ 11
HIC530-7T037G(B)						
HIC530-7T045G(B)						
HIC530-7T055G(B)						
HIC530-7T075G(B)	/	/	890	470	320	φ 12
HIC530-7T093G(B)						
HIC530-7T110G						
HIC530-7T132G	/	/	1130	540	376	φ 13
HIC530-7T160G						
HIC530-7T185G						
HIC530-7T200G						
HIC530-7T220G						
HIC530-7T250G	/	/	1400	700	396	14
HIC530-7T280G						
HIC530-7T315G						
HIC530-7T355G	/	/	1800	800	600	/
HIC530-7T400G						
HIC530-7T500G	/	/	1800	1000	600	/
HIC530-7T630G						
HIC530-7T710G						



Tab.2-4 Wall-mounted mode installation dimensions of HIC530 under 22KW

Model	Mounting hole		Wall-mounted hole dimension				Diameter of mounting hole (mm)
	A (mm)	B (mm)	H (mm)	H1 (mm)	W (mm)	W1 (mm)	
HIC530-3SR4G	88	157	160	140	93	73	Φ 4.5
HIC530-3SR75G							
HIC530-3S1R5G							
HIC530-3S2R2GB	108	185	192	168	116	92	Φ 4.5
HIC530-4TR75GB	88	157	160	140	93	73	Φ 4.5
HIC530-4T1R5GB/2R2PB							
HIC530-4T2R2GB/4R0PB	108	185	192	168	116	92	Φ 4.5
HIC530-4T4R0GB/5R5PB							
HIC530-4T5R5GB/7R5PB	128	239	245	221	136	112	Φ 5.5
HIC530-4T7R5GB/9R0PB							
HIC530-4T9R0GB/011PB	140	341	311	/	191	/	Φ 8
HIC530-4T011GB/015PB							
HIC530-4T015GB/018PB							
HIC530-4T018GB/022PB	150	392	415	/	219	/	Φ 8
HIC530-4T022GB/030PB							

2.6 Optional Parts

If the user needs such optional parts, please specify when placing the order.

Tab.2-5 HIC530 Inverters Optional Parts

Name	Model	Function	Remarks
Built-in brake unit	The letter “B” attached behind the product model	Braking	Built-in as standard
External LED operating panel	CM530-LED	External LED display and keyboard	HIC series universal The RJ45 interface
External LCD operating panel	CM530 -LCD	External LCD display and keyboard	The RJ45 interface
External LED2 operating panel	CM530 -LED2	The copy function keyboard with parameters	HIC series universal RJ45 interface
Extension cable	CM530 -CAB	Standard 8 core cable, can and CM530-LED, CM530-LCD, CM530-LED2 connection	Providing 1 meters, 3 meters, 5 meters, 10 meters, totally 4 kinds of specifications
If you need other function module extensions (such as: I/O card, PG card, EPS card and so on), please use the HIC580 series inverter, specifying the order function module card when ordering.			

2.7 Routine Repair and Maintenance of Inverter

2.7.1 Routine Repair

The influence of the ambient temperature, humidity, dust and vibration will cause the aging of the devices in the inverter, which may cause potential fault of the inverter or reduce the service life of the inverter. Therefore, it is necessary to carry out routine and periodical maintenance on the inverter.

Routine inspection Items include:

- 1) Whether there is any abnormal change in the running sound of the motor;
- 2) Whether the motor has vibration during the running;
- 3) Whether there is any change to the installation environment of the inverter;
- 4) Whether the inverter cooling fan works normally;
- 5) Whether the inverter has over temperature;

Routine cleaning:

The inverter shall be kept clean all the time.

The dust on the surface of the inverter shall be effectively removed, so as to prevent the dust entering the inverter. Especially the metal dust is not allowed.

The oil stain on the inverter cooling fan shall be effectively removed.

2.7.2 Periodic Inspection

Please perform periodic inspection on the places where the inspection is a difficult thing.

Periodic inspection Items include:

- 1) Check and clean the air duct periodically;
- 2) Check if the screws are loosened;

- 3) Check if the inverter is corroded;
- 4) Check if the wire connector has arc signs;
- 5) Main circuit insulation test;

Remainder: When using the megameter (DC 500V megameter recommended) to measure the insulating resistance, the main circuit shall be disconnected with the inverter. Do not use the insulating resistance meter to control the insulation of the circuit. It is not necessary to conduct the high voltage test (which has been completed upon delivery).

2.7.3 Replacement of Vulnerable Parts for Inverter

The vulnerable parts of the inverter include cooling fan and filter electrolytic capacitor, whose life depends on the operating environment and maintenance status. Common service life:

Part name	Life time
Fan	2 to 3 years
Electrolytic capacitor	4 to 5 years

The user can determine the term for replacement according to the running time.

1) Cooling fan

Possible causes for damage: bearing wearing and blade aging.

Criteria: Whether there is crack on the blade and whether there is abnormal vibration noise upon startup.

2) Filter electrolytic capacitor

Possible causes for damage of filter electrolytic capacitor: Poor input source quality, high ambient temperature, frequent load jumping and burning electrolyte.

Criteria: Whether there is liquid leakage, whether the safe valve has projected, measure the static capacitance, and measure the insulating resistance.

2.7.4 Storage of Inverter

Attention shall be paid to the following points for the temporary and long-term storage of the inverter:

- 1) Place the inverter back into the packing box following the original package;
- 2) Long-term storage will degrade the electrolytic capacitor. The product shall be powered up once every 2 years, and the power-up time shall be no less than 5 hours. The input voltage shall be increased slowly to the rated value with the regulator.

2.8 Warranty of Inverter

Free repair warranty is just for inverter itself.

1. Warranty instruction of product for domestic use.

- ① guarantee for repair, exchange and return of the inverter within 1 month after the delivery.
- ② guarantee for repair and exchange within 3 months after the delivery.
- ③ guarantee for repair with 15 months after the delivery or within 18 months after the date of production as indicated on the barcode.

2. Products exported to overseas area (excluding domestic area) have repair warranty on the purchase place with 6 month after the delivery.

3. Reasonable fees will be charged due to the expiration of the warranty period.

4. Reasonable fees will be charged for the following situations within the warranty period.
- ① The machine is damaged for the reason that the user didn't operate it according to the manual.
 - ② The damage is caused by force majeure like flood, fire or abnormal voltage etc.
 - ③ The damage is caused for the inverter been used in abnormal function.
 - ④ The P-type (fan, water bump type) inverter is used as the G-type (general type).
 - ⑤ Tear off the nameplate and serial number without authorization.
5. We only take responsibility for item 1 or item 2 if there were any product accident, for more compensation, please insure for the goods previously for property insurance.

The service charge is counted according to the standard rules made by the company; the contract takes the priority if there is any agreement previous.

2.9 Guide to Select Brake Components

What in below Tab.2-6 are the guide data, the user can choose different resistance and power according to the practical situation, (the resistance value must not less than the recommended one; the power value can be more) the brake resistance should be chosen according to the real power of the motor when used in practical system. It is related to system inertia, speed decelerating time and potential energy load etc, the customer should choose it based on the real circumstance. The bigger inertia of the system; the shorter time of speed decelerating; the more frequent of the brake; the bigger power and smaller resistance of the brake resistor need to be with.

2.9.1 How to choose the resistance

When braking, almost all the recovery energy of the motor is spent on the braking resistance. It follows the formula: $U \cdot U/R = P_b$

U---the braking voltage of the stable braking system (the value is different in different system. Generally for 380VAC, the value is 700V)

P_b---the braking power

2.9.2 How to choose the power of the braking resistor

The power of the braking resistor is same as the braking power theoretically, but taking into consideration that the derating is 70%. It follows the formula: $0.7 \cdot P_r = P_b \cdot D$

P_r---the power of the braking resistor

D---the braking ratio (the ratio which the reactivation process divides the whole working process), generally take 10% as its value. You can refer to the details in below chart.

Application industry	elevator	Winding and unwinding machine	centrifuge	Accidental braking load
ratio	20% ~30%	20~30%	50%~60%	5%

Tab.2-6 selection of HIC530 inverter brake components

Inverter model	Braking torque 150%,5S recommended resistance value, power and brake unit model	Braking torque 100%,15S recommended resistance value, power and brake unit model	Braking torque 50%,15S recommended resistance value, power and brake unit model
HIC530-3SR4G	$\geq 220 \Omega$, 100W Optional brake unit	$\geq 300 \Omega$, 80W Optional brake unit	$\geq 300 \Omega$, 80W Optional brake unit
HIC530-3SR75G	$\geq 200 \Omega$, 100W Optional brake unit	$\geq 200 \Omega$, 100W Optional brake unit	$\geq 300 \Omega$, 80W Optional brake unit
HIC530-3S1R5G	$\geq 100 \Omega$, 200W Optional brake unit	$\geq 200 \Omega$, 100W Optional brake unit	$\geq 300 \Omega$, 80W Optional brake unit
HIC530-3S2R2GB	$\geq 75 \Omega$, 0.4KW build-in brake unit	$\geq 130 \Omega$, 0.2KW build-in brake unit	$\geq 150 \Omega$, 0.2KW build-in brake unit
HIC530-3S4R0GB	$\geq 60 \Omega$, 0.3KW build-in brake unit	$\geq 75 \Omega$, 0.4KW build-in brake unit	$\geq 100 \Omega$, 0.2KW build-in brake unit
HIC530-3S5R5GB	$\geq 40 \Omega$, 0.8KW build-in brake unit	$\geq 50 \Omega$, 1.5KW build-in brake unit	$\geq 60 \Omega$, 0.3KW build-in brake unit
HIC530-4TR75GB	$\geq 300 \Omega$, 0.2KW build-in brake unit	$\geq 300 \Omega$, 0.2KW build-in brake unit	$\geq 300 \Omega$, 0.2KW build-in brake unit
HIC530-4T1R5GB/2R2PB	$\geq 150 \Omega$, 0.3KW	$\geq 220 \Omega$, 0.25KW	$\geq 300 \Omega$, 0.2KW
HIC530-4T2R2GB/4R0PB	build-in brake unit	build-in brake unit	build-in brake unit
HIC530-4T4R0GB/5R5PB	$\geq 100 \Omega$, 0.4KW build-in brake unit	$\geq 130 \Omega$, 0.4KW build-in brake unit	$\geq 150 \Omega$, 0.3KW build-in brake unit
HIC530-4T5R5GB/7R5PB	$\geq 75 \Omega$, 0.5KW build-in brake unit	$\geq 100 \Omega$, 0.4KW build-in brake unit	$\geq 130 \Omega$, 0.4KW build-in brake unit
HIC530-4T7R5GB/9R0PB	$\geq 60 \Omega$, 0.5KW build-in brake unit	$\geq 75 \Omega$, 0.5KW build-in brake unit	$\geq 100 \Omega$, 0.4KW build-in brake unit
HIC530-4T9R0GB/011PB	$\geq 40 \Omega$, 1.0KW	$\geq 50 \Omega$, 0.7KW	$\geq 60 \Omega$, 0.5KW
HIC530-4T011GB/015PB	build-in brake unit	build-in brake unit	build-in brake unit
HIC530-4T015GB/018PB	$\geq 30 \Omega$, 1.2KW build-in brake unit	$\geq 40 \Omega$, 1.0KW build-in brake unit	$\geq 50 \Omega$, 0.7KW build-in brake unit
HIC530-4T018GB/022PB	$\geq 24 \Omega$, 2KW build-in brake unit	$\geq 30 \Omega$, 1.2KW build-in brake unit	$\geq 40 \Omega$, 1.0KW build-in brake unit

Inverter model	Braking torque 150%,5S recommended resistance value, power and brake unit model	Braking torque 100%,15S recommended resistance value, power and brake unit model	Braking torque 50%,15S recommended resistance value, power and brake unit model
HIC530-4T022GB/030PB	$\geq 13.6 \Omega$, 3.7KW build-in brake unit	$\geq 30 \Omega$, 1.2KW build-in brake unit	$\geq 40 \Omega$, 1.0KW build-in brake unit
HIC530-4T030G(B)/037P(B)	$\geq 13.6 \Omega$, 3.7KW Brake unit built-in as optional	$\geq 24 \Omega$, 2KW Brake unit built-in as optional	$\geq 30 \Omega$, 4KW Brake unit built-in as optional
HIC530-4T037G(B)/045P(B)	$\geq 10 \Omega$, 4.5KW BR530-4T075	$\geq 24 \Omega$, 2KW BR530-4T037	$\geq 24 \Omega$, 2KW BR530-4T037
HIC530-4T045G(B)/055P(B)	$\geq 6.8 \Omega$, 8.0KW BR530-4T132	$\geq 10 \Omega$, 4.5KW BR530-4T075	$\geq 13.6 \Omega$, 3.7KW BR530-4T075
HIC530-4T055G(B)/075P(B)			
HIC530-4T075G(B)/093P(B)			
HIC530-4T093G(B)/110P(B)	$\geq 2*(6.8 \Omega, 8.0KW)$ BR530-4T200	$\geq 6.8 \Omega$, 8.0KW BR530-4T132	$\geq 6.8 \Omega$, 8.0KW BR530-4T132
HIC530-4T110G/132P			
HIC530-4T132G/160P			
HIC530-4T160G/185P	$\geq 3*(6.8 \Omega, 8.0KW)$ BR530-4T315	$\geq 2*(6.8 \Omega, 8.0KW)$ BR530-4T200	$\geq 2*(6.8 \Omega,$ 8.0KW) BR530-4T200
HIC530-4T185G/200P			
HIC530-4T200G/220P			
HIC530-4T220G/250P	$\geq 3*(6.8 \Omega, 8.0KW)$ BR530-4T315	$\geq 2*(6.8 \Omega, 8.0KW)$ BR530-4T315	$\geq 2*(6.8 \Omega,$ 8.0KW) BR530-4T315
HIC530-4T250G/280P			
HIC530-4T280G/315P			
HIC530-4T315G/355P			
HIC530-4T355G/400P	$\geq 5*(6.8 \Omega, 8.0KW)$ BR530-4T630	$\geq 4*(6.8 \Omega, 8.0KW)$ BR530-4T450	$\geq 3*(6.8 \Omega, 8KW)$ BR530-4T450
HIC530-4T400G/450P			
HIC530-4T450G			
HIC530-4T500G	$\geq 6*6.8\Omega, 20KW$ BR530-4T630	$\geq 5*6.8\Omega, 20KW$ BR530-4T630	$\geq 4*6.8\Omega, 20KW$ BR530-4T630
HIC530-4T550G			
HIC530-4T630G			

Attention:

1. The braking resistance value can't be less than the recommended data, if it exceeding the recommended data it may damage the braking unit.

2. What's in the table “×2” means 2 brake resistor used in parallel, “×3” means 3 brake resistor used in parallel. For others can be done in the same manner.
3. It's the standard build-in brake unit inverter model if there is a “B” following after the model name, if not, no build-in brake unit. Please choose the corresponding brake unit model according to the brake torque.
4. 18.5~30KW selectable build-in brake unit of G type inverter. Please declare it on the order requirement that you need the standard configuration without brake unit if it's needed.
5. What in the tale “5S, 15S” means the continuous braking time.