



It is all about Quality
SWISS Quality



HOFFMANN Technics AG

St.Gallen
Switzerland

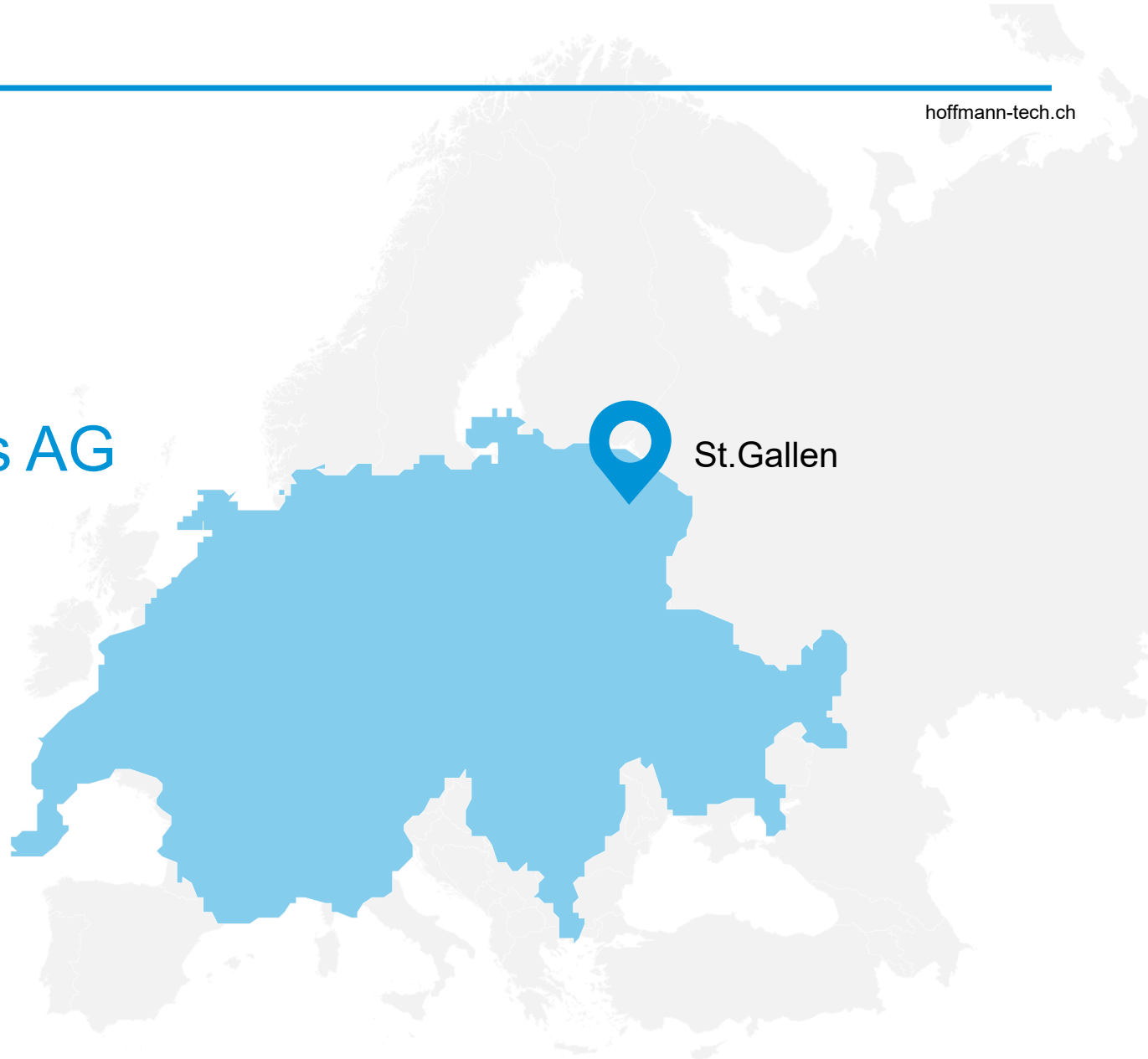





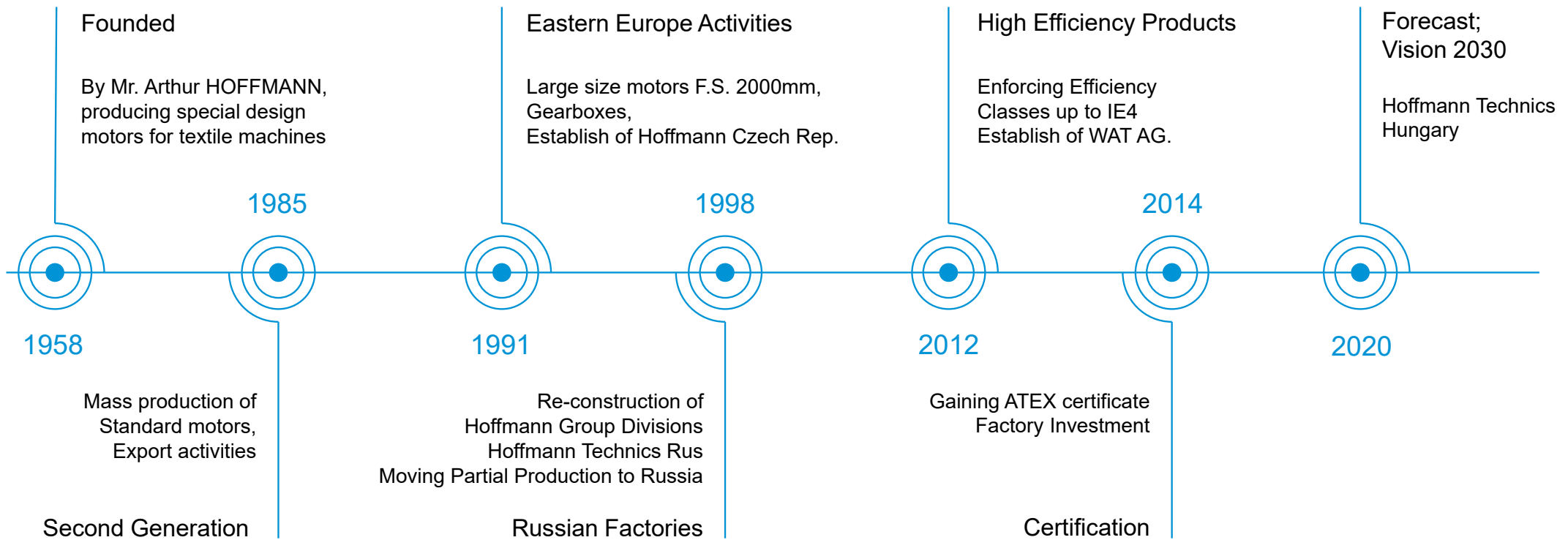

Hoffmann's Mile stones







Hoffmann Group of Companies

-  HOFFMANN Technics AG,
Switzerland
-  Hoffmann Technics Rus Ltd.
Russia
-  Hoffmann Elektrik Power,
Czech Republic
-  Hoffmann Technics Kft.
Hungary
-  WAT AG,
Switzerland



-  RUSELPROM
Russia
-  CEBA Ingranaggi
Italy

Steady Growth in Product Range



Affiliation and Membership



Schweizer Technischer
Verband



Schweizer
Elektrotechnischer Verein



Industrie- &
Handelskammer



Commissioned by the Swiss
Government for Swiss Product
Promotions



Swiss Export Risk Insurance
Federal Support for Swiss Product
Promotions



Sales Volume

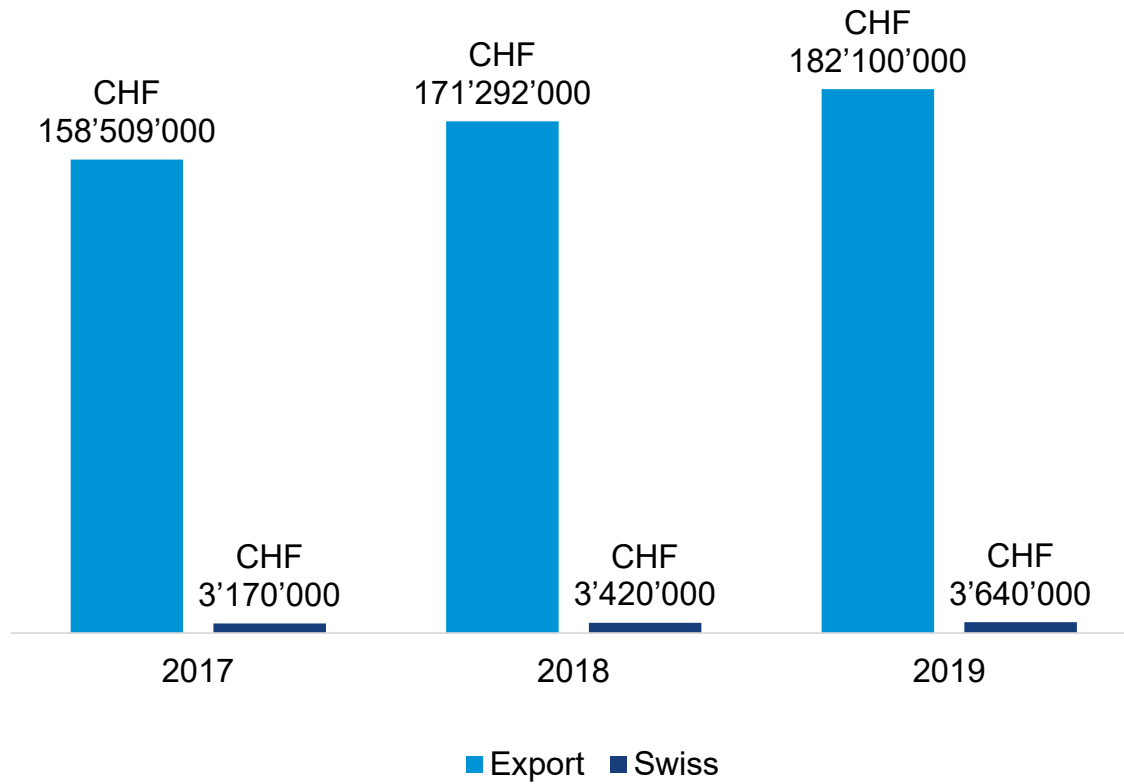

Export > 98%



Research and Development

*Your Problem is our **Challenge**
Your **Success** is our Aim*

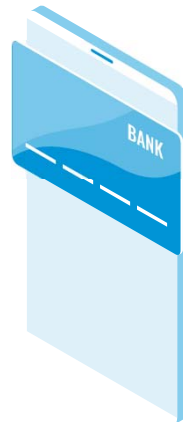

invests

20%

of its yearly NET Profit in



Research and Development

*Your Problem is our **Challenge**
Your **Success** is our Aim*



invests

20%

of its yearly NET Profit in



Research and Development

*Your Problem is our **Challenge**
Your **Success** is our Aim*

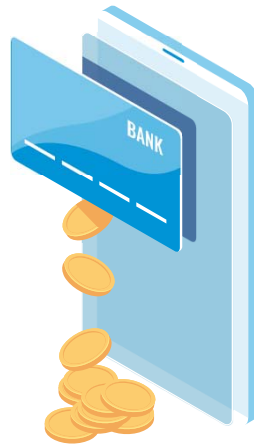

invests

20%

of its yearly NET Profit in



Research and Development

*Your Problem is our **Challenge**
Your **Success** is our Aim*

invests
20%
of its yearly NET Profit in

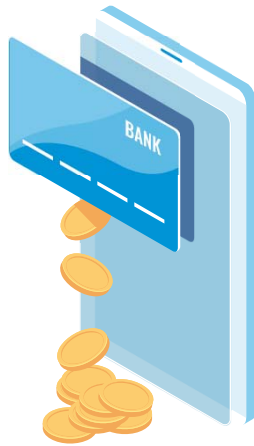

Development

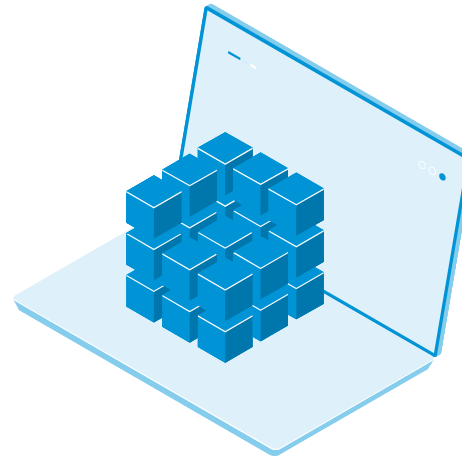

&

Research





Wide Range





Our Activity

Electric Drives

- Three Phase AC Motor
- Synchronous Motor
- Synchr. & Asynchronous Generators
- DC Motor
- Gearboxes in Helical, Bevel, Parallel-shaft or Variable Speed.
- Variable Speed Frequency Drives, Soft-starters , Excitation & Monitoring systems.
- Engineering & Consulting for Customized Solutions or innovations
- Tailor-made Motors



Three Phase **Motors**

- Induction Squirrel Cage Motor in, IEC, NEMA and GOST Standards
- Slip-Ring Motor (Low and High Voltage)
- Explosion-proof Motor in IEC, NEMA and GOST
- Brake Motor
- Marine Motor





Our Products

your benefit Strength

L.V. Range

Housing HJ: HOFFMANN Tradition
Housing HM: Improved Version

Terminal box = 4 x 90°
Cable Entry = 4 x 90°

Range 0.37 – 1400kW





Induction and Slip Ring Motors

Medium & High Voltage Motors up to 32MW. Frame size 2000mm



Open Drip Proof



Tube Ventilated



Air - Water



Fan Cooled



Air - Air



DC Motors

- Production of up to 10MW
- Frame size: 2000mm.
- IP 23 / IP 55
- Isol. Cl. F / Cl. H
- Cooling Method
IC01, IC23, IC81W, IC611,...etc

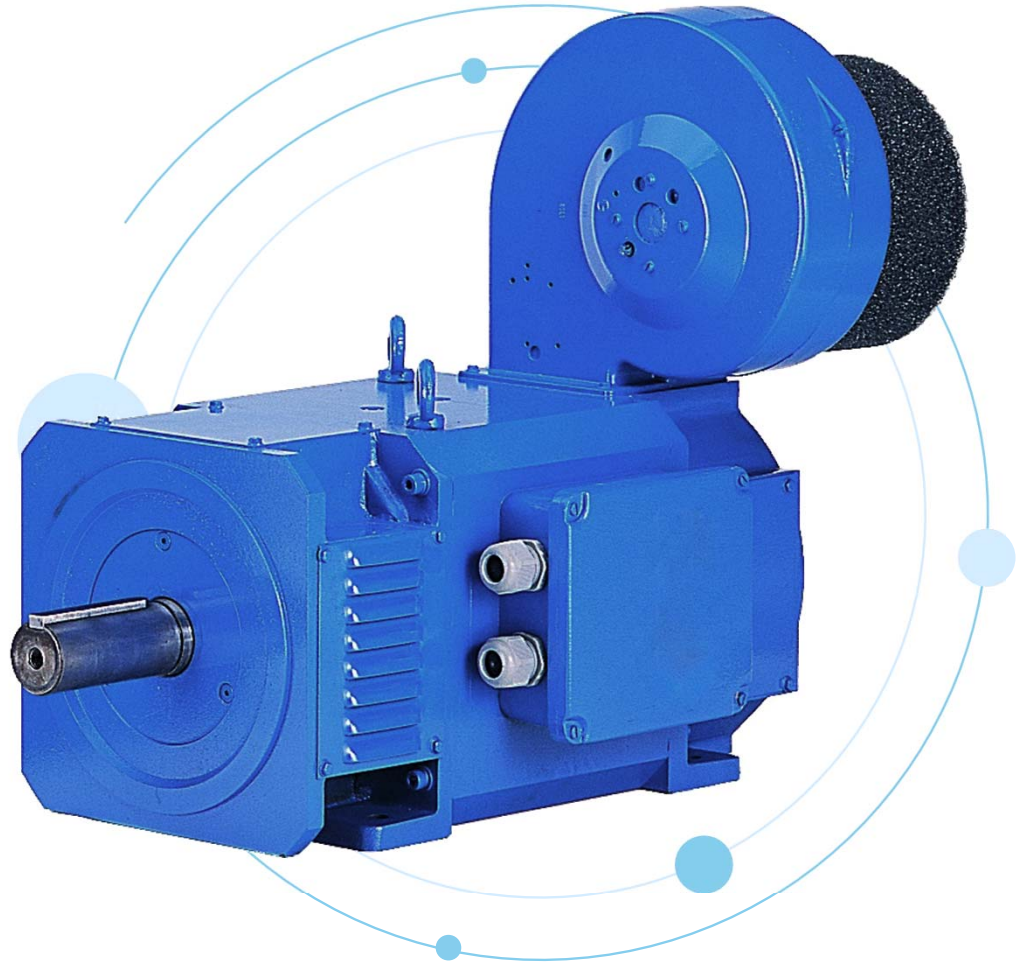



Explosion-Proof Motors

- Low and High Voltage Ex - Motor
- Explosion-Proof methode Exn, Exe, Exp, Exd.
- ATEX Certificate issued by NEMKO-DNV-PreSAFE
- New serie of Aluminum Housing Explosion-Proof



ATEX Certificate

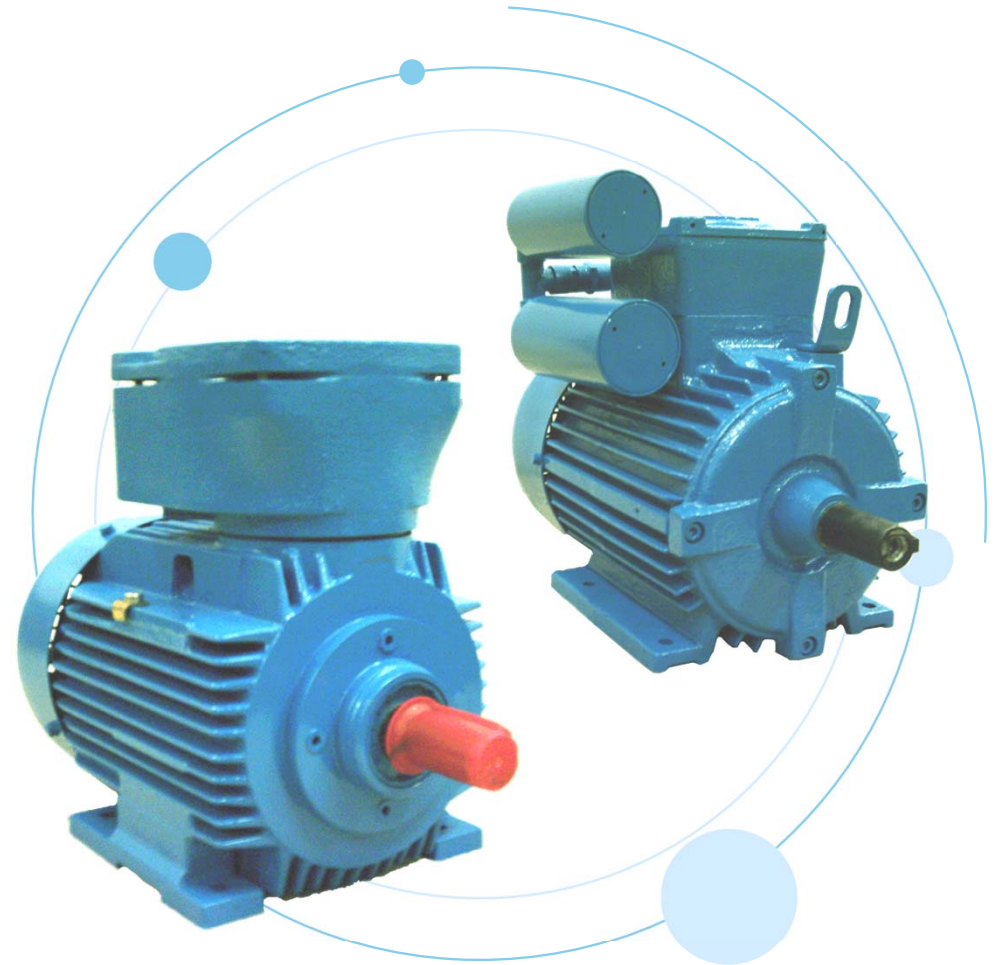

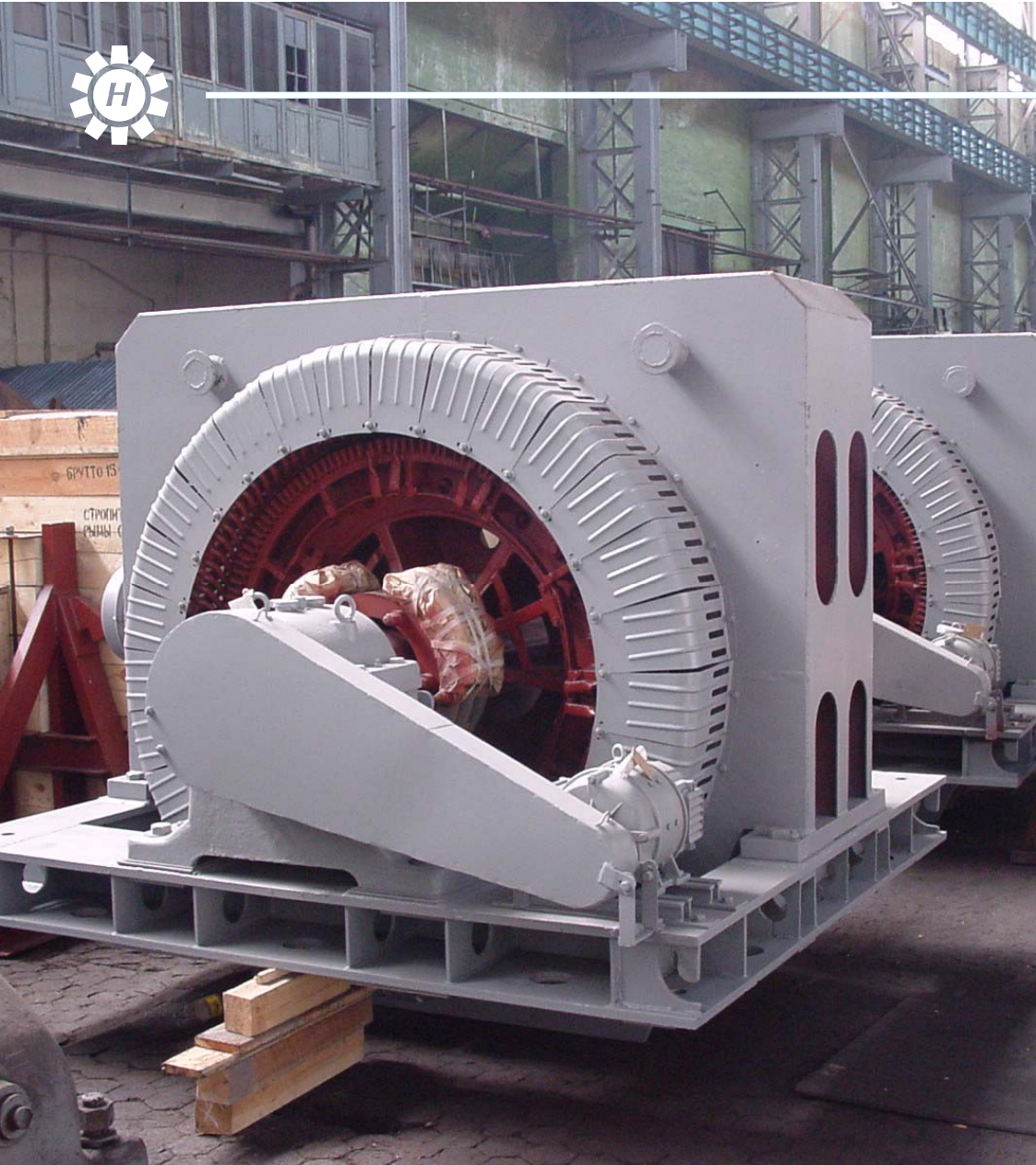

Synchronous Motors

- Product range up to 20MW
- Fixed Speed, high Torque with starting current limited to 350 -500 % of the rated current.
- Converter fed variable speed allows increased efficiency and improved motor torque.
- Speed from 60 to 3000 R.P.M
- Cooling Method:
Open Air, Air-to-Water and Air-to-Air



Generators

- Product range up to 250MW
- Low & High Voltage up to 13.8kV
- Number of Poles 2 – 8
- Application: Gas / Diesel / Hydro.



Variable Frequency Drives, Soft Starters and Excitation & Monitoring Systems



- L.V. & H.V. Frequency Converters up to 25MW
- Soft-Starter up to 25MW
- Excitation Systems up to 3500Amp. Either Static or Brushless.
- Brushless Fixed Speed excitor with Automatic Voltage Regulator
- A Variable Speed System with brushes and Slip-ring unit.



Innovations Integrated Frequency Inverter

- Saving Space
- Energy –saving, Lots of Benefits

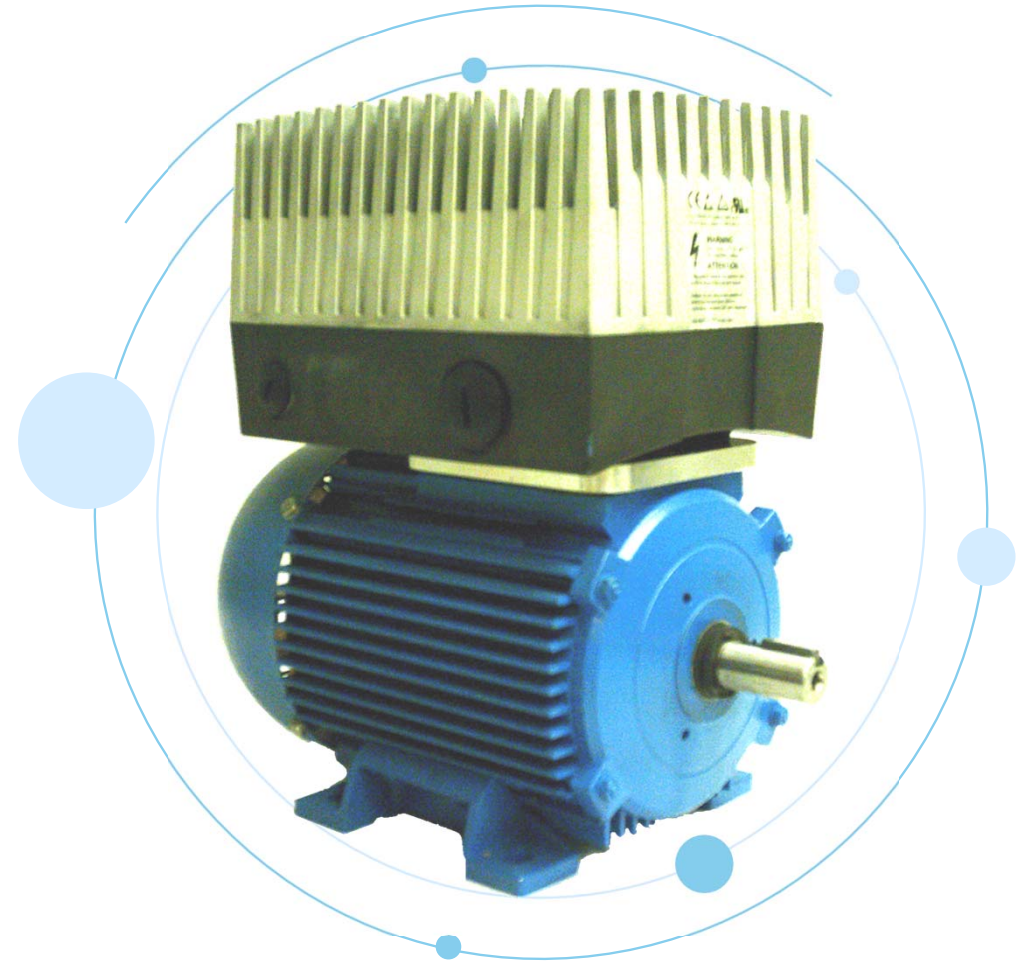



Our Products
your benefit Strength

Electric Drives

Selection of Tailor-made Electric Harmony for
more than 60 Years Experience.

Engineering & Consulting for Customized
Solutions or innovations

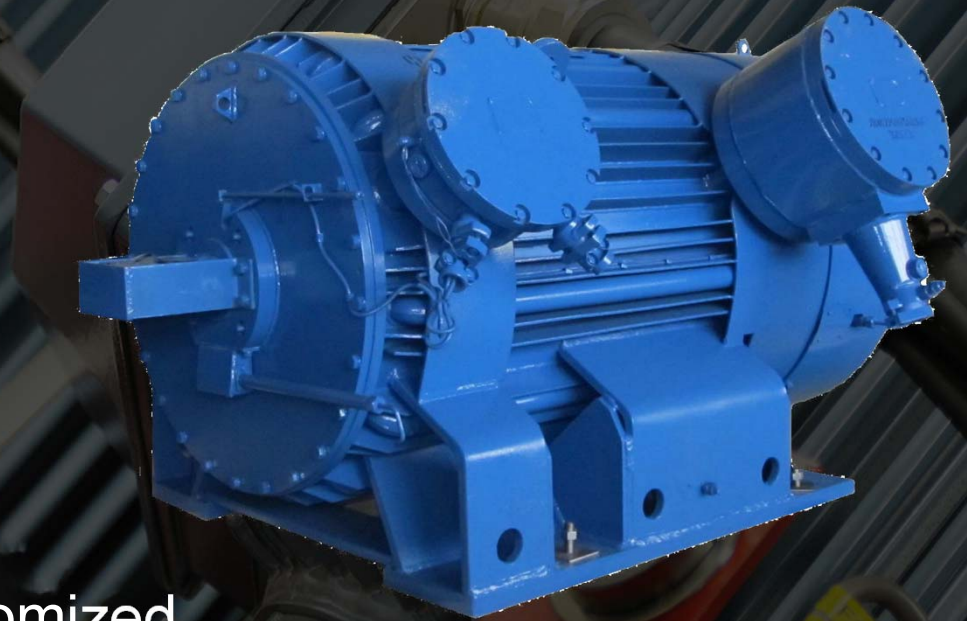



Tailor-Made Drives

- Special Expertise in Design and Production of Special Execution of Complete Drive according to Applications and Customer's Request.

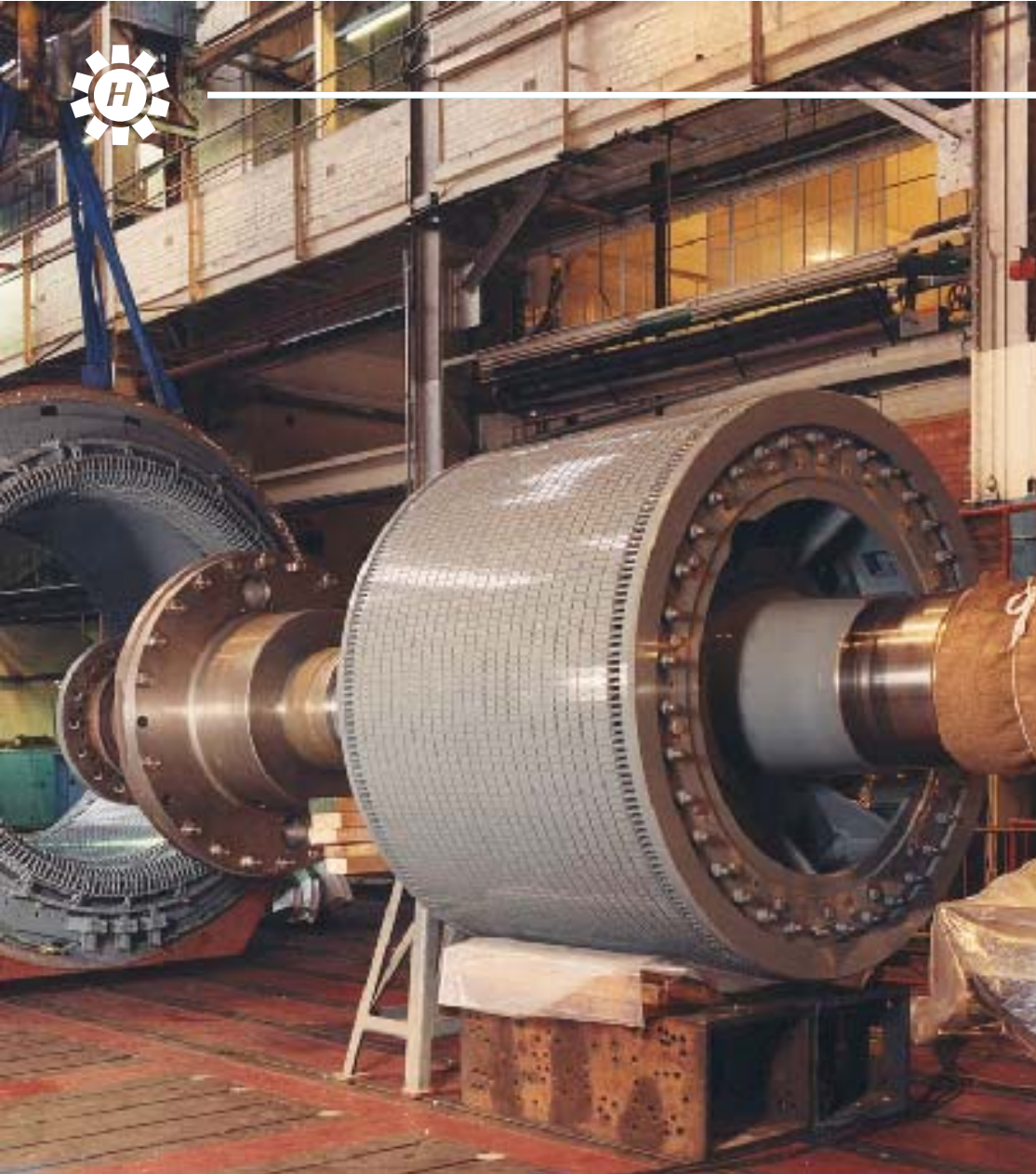



Experience in Replacement of **Motors**

Replacement



Application Studies

Analyze of in & out of the motor

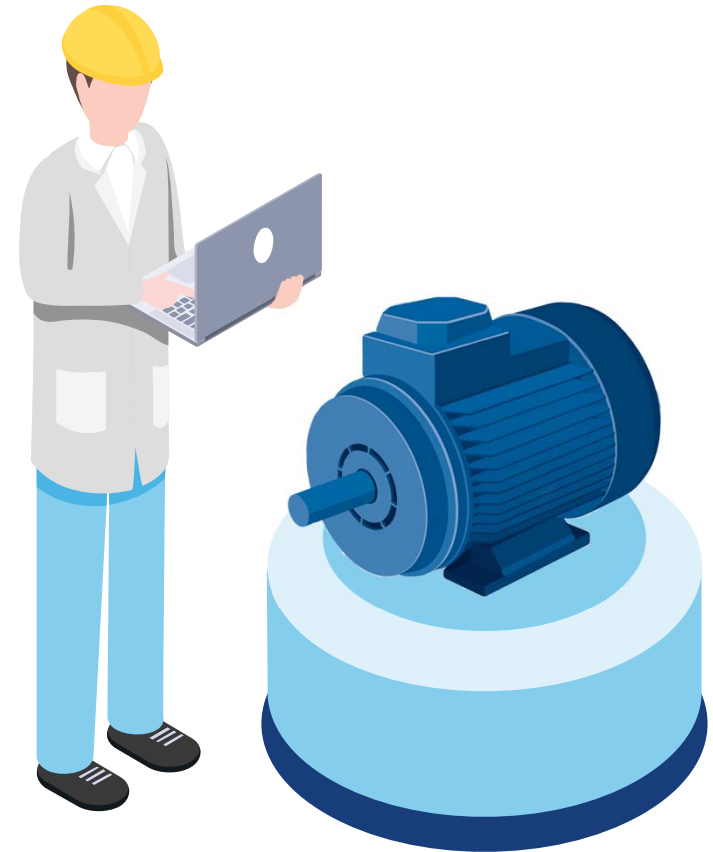



Application Analysis

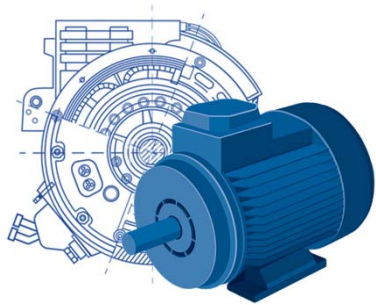

Re-design



Operating Conditions

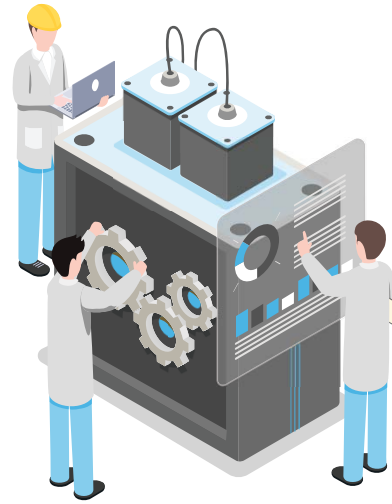

Driving Machine

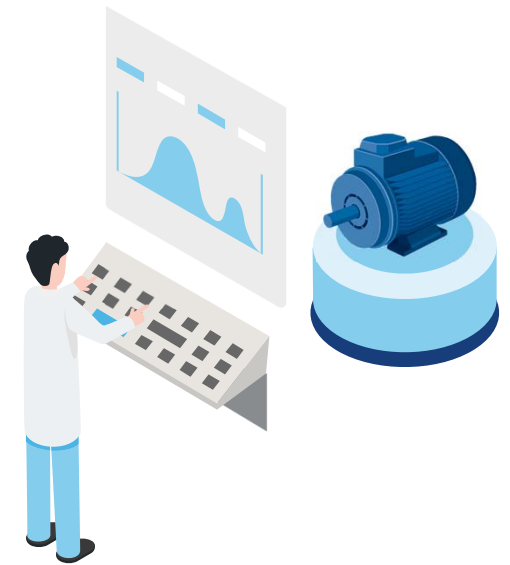

Control & Protection



Round Table Meetings

- Site Visits by Designer Engineer
- Exchange of Information
- Discussion of (Problems- Possible improvement)
- Evaluation of the operating conditions and application
- Analyzed them technically and dimensionally

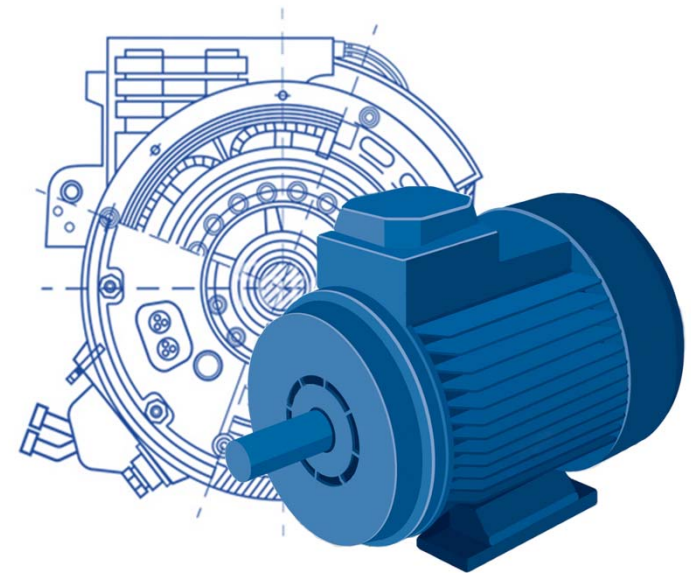



Commissioning – Start-up

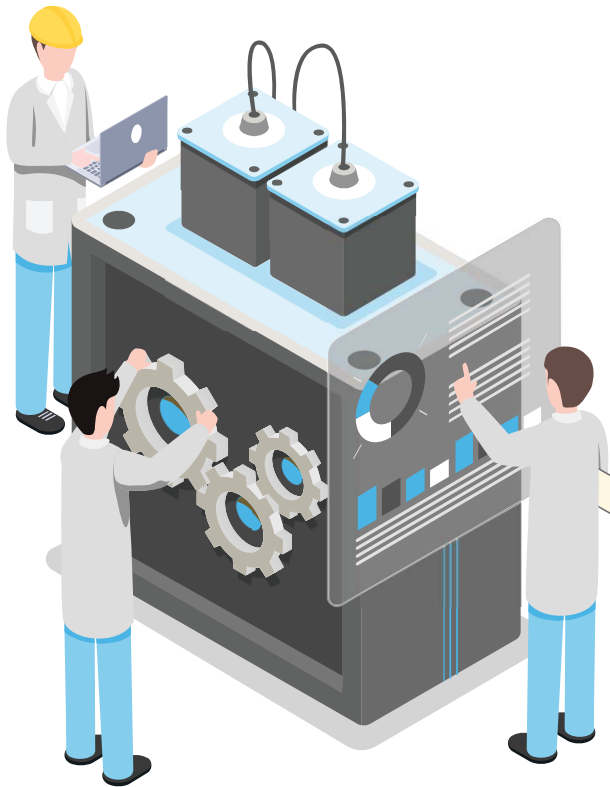

Our engineers will attend the installation of each motor offering technical assistance and necessary support that may be required to ensure a problem-free installation and a

100% operation of motors.

Trouble Free Operation on Full Load



Options

- High Efficiency Class IE4
- Insulation Cl. H
- Protection in IP 67 (IP 68)
- Reinforced Bearings
- Extern Ventilation
- Monitor & tripping Sensors
- Surge / Lightning Arrestors
- Dial Thermometers
- Vibration Monitor Systems
- Power Factor Correction
- Anti-Corrosive C5M standards (ISO 12864-5)





Harsh Environment

- Inner and outer anti-corrosive treatment according to International C5M standards (ISO 12864-5)
- Stainless Fasteners
- Silicon Sponge Gasket -Seals
- Cooler's Pipes made from Titanium or Stainless Steel 316L
- Stator painted with Epoxy zinc-rich prime paint
- Rotor painted by an Epoxy resin/micaceous iron.
- Housing Painted with Epoxy primer and Polyurethane topcoats min. thickness 240 μm

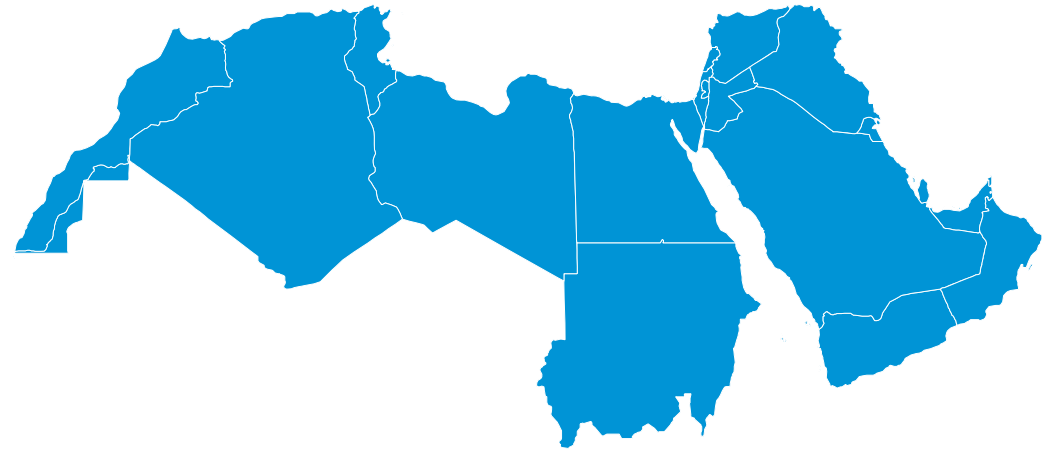



Our Products
your benefit Strength

Gearboxes

from Hoffmann Technics AG
Variety, Flexibility, Reliability

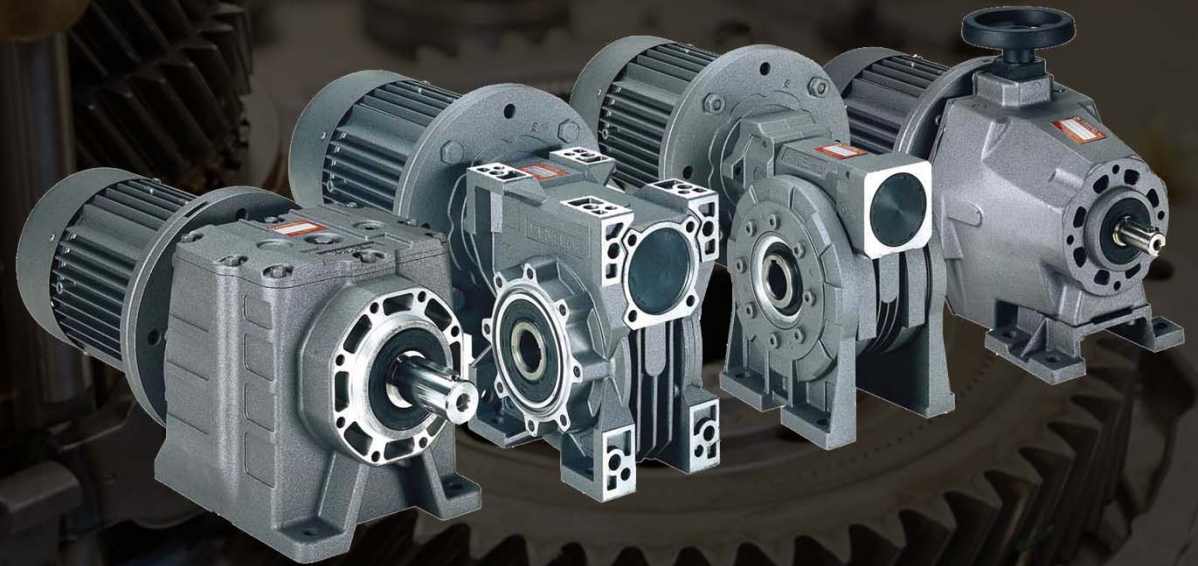



Gearbox Motors

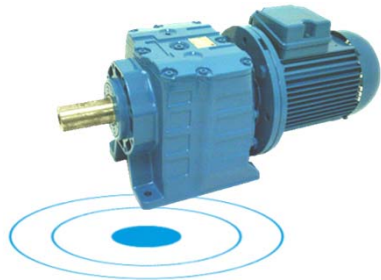

- Production till 160 KW – 15000 Nm
- Aluminium, Cast-Iron or Steel
- Housings Individually

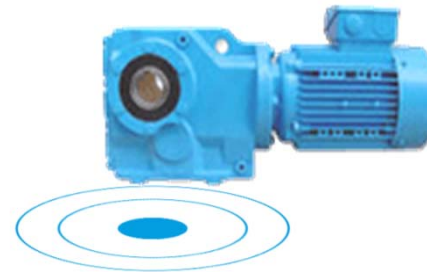

- Production till 160 KW – 42000 Nm
- Cast-Iron Housing with Hollow / Solid Shaft



Gearbox Motors

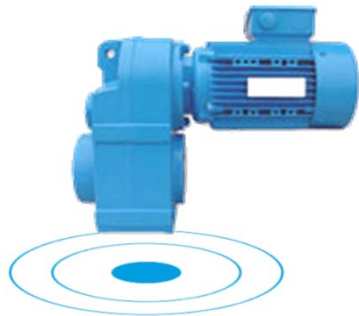

- Production up to 160 KW – 15000 Nm
- Cast-Iron Housing with Hollow / Solid Shaft

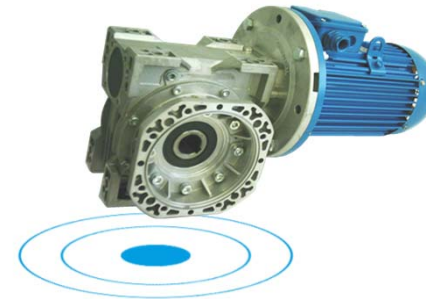

- Production till 22 KW – 3000 Nm
- Aluminium Housing till 4 KW
- Cast-Iron Housing with Hollow / Solid Shaft



Variable-Speed Gearbox Motor

- Heavy Industrial Application
- Reduction ratio 1 – 5 in Cast-Iron





GEARBOX

- Production of Special Execution of Gearbox Units. Fulfil almost Every Request.
- Production up to 10000 kW and weight of 50 Tons





Various Applications

- Water & Irrigation
- Crusher, Mill, Kiln, Belt Conveyor, Excavator.
- Mining, Cement, Cranes, Press.
- Oil & Gas Industry
- Chemical Industry Machines
- Thermal & Hydro Power Stations
- Nuclear Stations



After Sales Services



Monitor & Observation

Qualified Engineers perform Inspection and Condition Analysis



Why HOFFMANN Technics?



Highest
Technology Standards



Competitive price

High Reliability – Pure
Premium raw material



Our Strength
Our Expertise

High efficiency –
Low cost operation



Our Philosophy



hoffmann-tech.ch

Hoffmann Technics AG
St.Gallen
Switzerland

Thank you for your
Attention

