



SIEMENS

Ingenuity for life

SIMOPRIME partnering

Reliable medium-voltage switchgear for
fail-safe operation, up to 24 kV



[siemens.com/simoprime-partner](https://www.siemens.com/simoprime-partner)

SIMOPRIME partnering concept



The SIMOPRIME partnering concept

We would like to invite you to join us in a strategic technology partnership. With a global brand in your area, we can work together to capture new markets and increase the profitability, volume and market share by our combined business.

SIMOPRIME is based on an air insulated medium-voltage switchgear technology featuring a modular design. The concept can be tailored to meet requirements of partners, and includes a graded value adding system for SIMOPRIME. SIMOPRIME partnering uses the newest vacuum circuit breaker (VCB) product line from Siemens.

Usage of state-of-the-art makes SIMOPRIME product future proof and highly sustainable.

Simplistic design of SIMOPRIME switchgear makes it easier to produce without high investments and return of the investment phase will be shorter for the investors.

The partnering concept has its own SIMOPRIME partnering label. This label stands for high potential, success and diversification. Using must buy parts from Siemens, e.g. earthing switches, bushings, contact fingers etc. ensures the fail safe operation of the SIMOPRIME switchgear.

- High quality
- High level of safety
- Type-tested system and components according to IEC 62271-200
- Modular design

- Simultaneous switching and MV components
- Configuration software
- Quality assurance
- Mechanical and electrical assembly

- Order management
- Production and assembly relevant descriptions
- Technical documentation

- Support
- Application of the configuration software
- Support at production stage
- Marketing support

SIMOPRIME switchgear, up to 17.5 kV and up to 24 kV

- Factory-assembled, type-tested switchgear according to IEC 62271-200
- Use of high quality, world-wide available components
- Design based on global best practice and 50 years of experience

SIMOPRIME features

- Interlockings between high-voltage door and switching devices
- Rack-in, rack-out operations of the circuit-breaker truck with high-voltage door closed
- Metallic, earthed shutters and partitions, partition class: PM (metallic partition)
- Use of metallic, earthed shutters and partitions between the compartments
- Highest loss of service continuity of the switchgear (LSC2B according to IEC 62271-200) during maintenance
- Internal arc tested design according to IEC 62271-200, 17.5 kV up to 40 kA, 1 s
- Internal arc tested design according to IEC 62271-200, 24 kV, up to 25 kA, 1 s
- Use of maintenance-free vacuum circuit breakers
- Flexibility due to two types of withdrawable unit design
 - Withdrawable (cassette) type*
 - Truck type
- Easy production of SIMOPRIME switchgear due to basic design without need of complex jigs and fixtures
- Safe operation due to high-voltage door closed during all switching operations, including emergency manual operations

* only available up to 17.5 kV

Benefits for your customer

- Saves lives
- Fast return of investment
- Peace of mind due to fail-safe operation
- Siemens product DNA
- Tens of thousands air-insulated, medium-voltage SIMOPRIME switchgears in operation world-wide prove that technologically sophisticated solutions can be efficiently implemented with the SIMOPRIME switchgear.

SIMOPRIME switchgear

17.5 kV version



02
Training



The right knowledge serves as a good basis

Our training centres in Gebze (Turkey) and Leipzig (Germany) offer a wide range of training sessions for your employees that can be individually adapted to your demands. Our training is based on many years of experience in the production of medium-voltage switchgears. Profound knowledge is the base for a successful start up.

Additional training options

- Power engineering and SIMOPRIME switchgear applications for medium-voltage networks
- Selection criterias for medium-voltage components
- CT and VT selection criterias
- Assembly and installation course (supervisor course)

Product training

- General characteristics and applications
- Features and components

Software training

- Offer, order and project structure, basic parameters of the switchgear design
- Switchgear and component selection
- Technical product documentation

Quality assurance

- Basic knowledge for production quality
- Best practice examples
- Information about type tests and routine testing

Assembly training

- Panel assembly with documentation
- Supporting tools and equipments
- Application examples

03
Configuration software

The configuration tool supports during the whole project - from offering and ordering up to assembly and documentation.

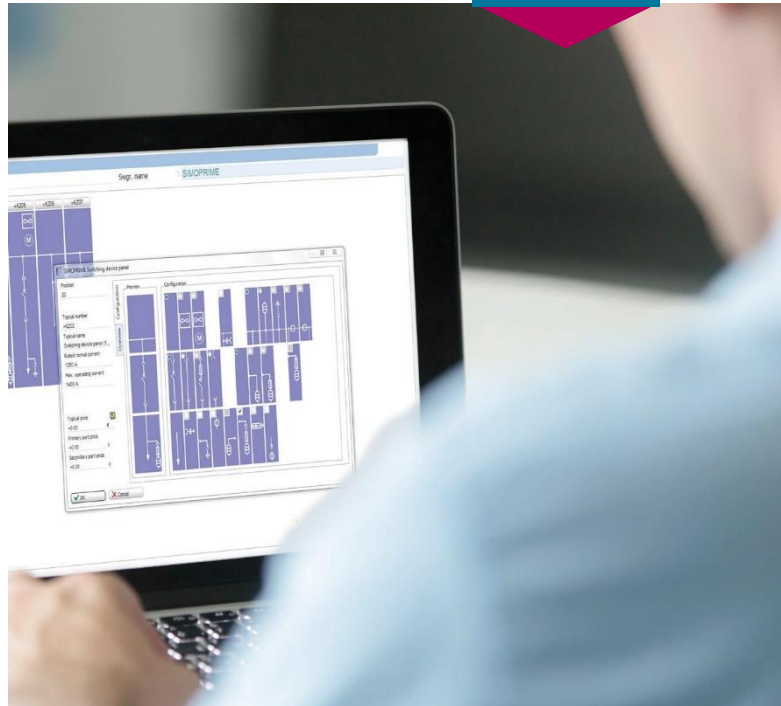

Time saving and error free configuration

The Siemens tools for SIMOPRIME air-insulated medium-voltage switchgear engineering are suitable for intuitive and error-proof primary part engineering.

Background algorithm avoids failures. The tools can be used during the quotation and order stages. The related documentation can be generated automatically, and manual modifications are only necessary with nonstandard designs.

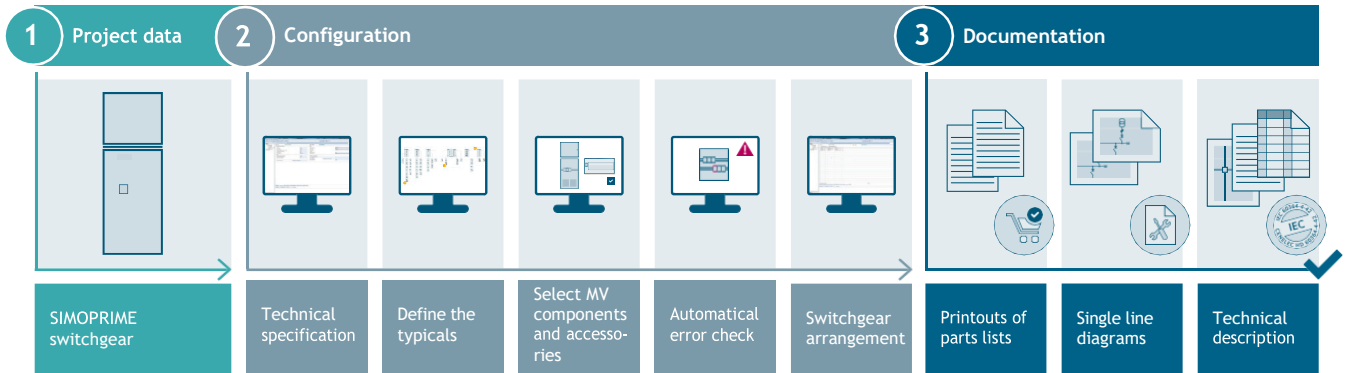

04
Service & Support



Exclusive support for our SIMOPRIME Technology Partner contributes to quick and successful project realization.

Priority technical support

We provide full scale technical assistance for configuration and manufacturing stages as well as in your first planning stage. Contact our Partnering Support Team by email: mv-partnering-support.de@siemens.com

Global support service

- User protected extranet for the partners to share the information such as test certificates, technical documents, datasheets and CAx data.
- Exclusive marketing support such as brochures, presentations, text modules, pictures for your catalogue or internet presence, etc.
- Regular Email newsletters and webinars provide you with the latest information about our products, systems and tools.
- Our internet website siemens.com/simoprime-partner highlights the concept and benefits of being a SIMOPRIME Technology Partner.

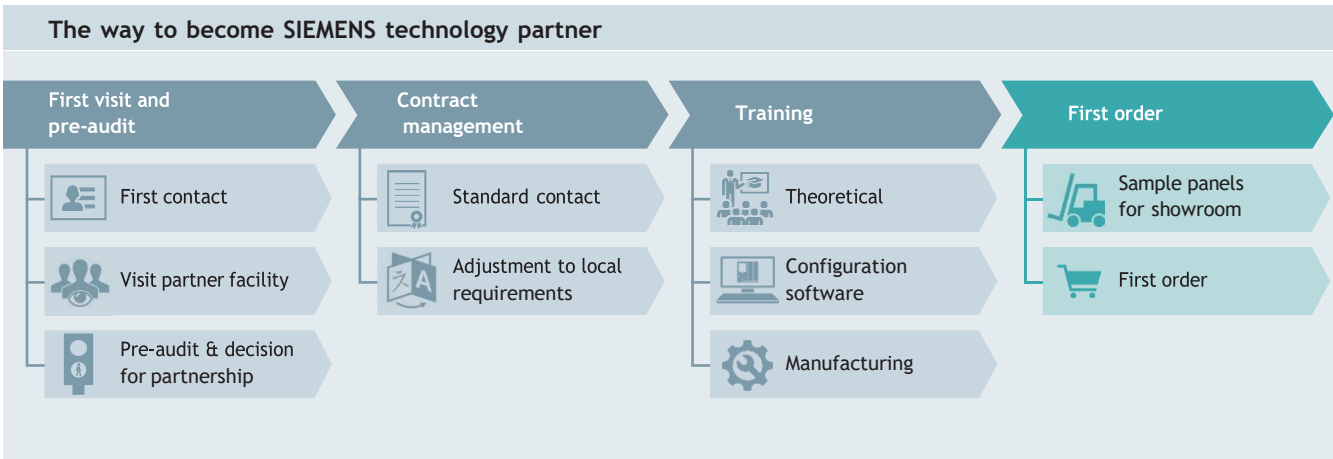

SIMOPRIME air-insulated medium-voltage switchgear

Technical specifications



Modular, reliable and safe:
air-insulated switchgear
for distribution and
industrial applications
up to 17.5 kV / up to 24 kV

Standards

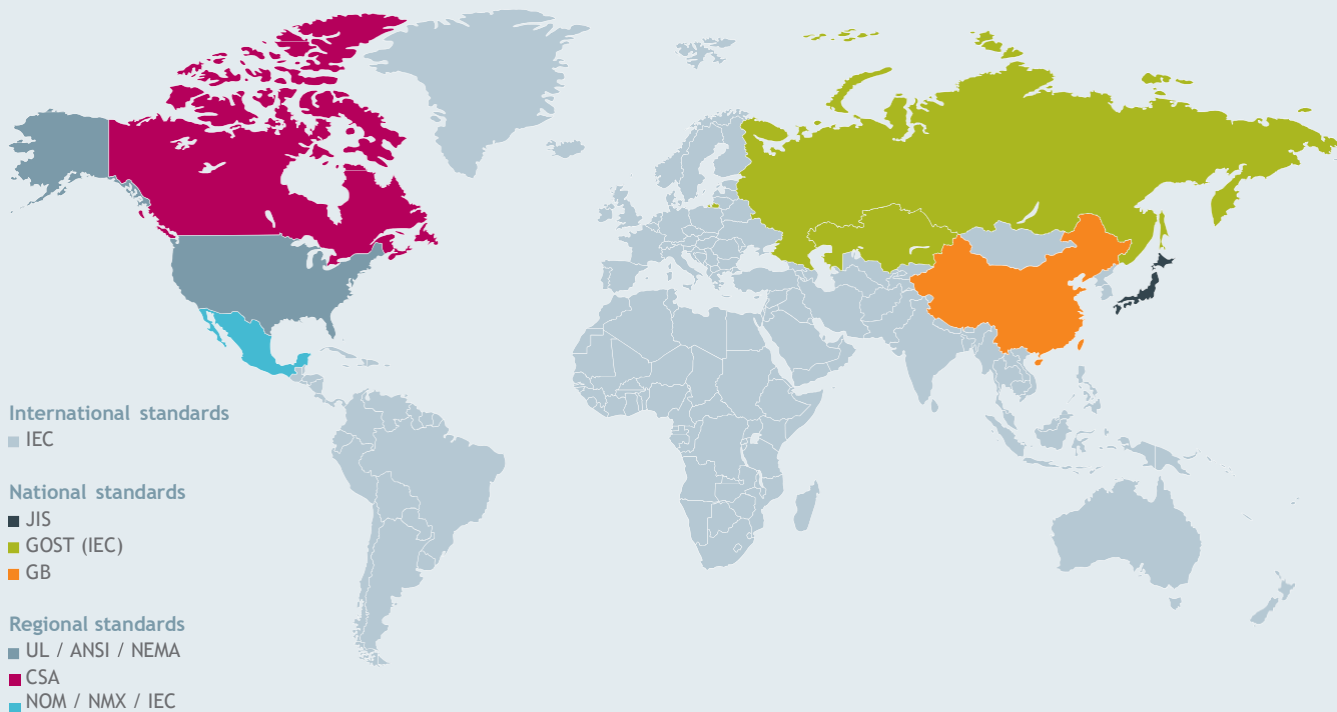

SIMOPRIME switchgears are fully type-tested to comply IEC standards as well as DIN and GOST standards.



Technical specification

SIMOPRIME switchgear					
Rated voltage	kV	7.2	12	17.5	24
Rated frequency	Hz	50/60	50/60	50/60	50/60
Rated short-duration power-frequency withstand voltage	kV	20 ¹⁾	28 ¹⁾	38	50
Rated lightning impulse withstand voltage	kV	60	75 ³⁾	95	125
Rated short-time withstand current in 3 s	kA	40	40	40	25
Rated peak withstand current at 50/60 Hz	kA	100/104	100/104	100/104	63
Rated short-circuit breaking current	kA	40	40	40	25
Rated short-circuit making current at 50/60 Hz	kA	100/104	100/104	100/104	63
Rated normal current of busbar	A	3.600	3.600	3.600	2.500
Rated normal current of feeders					
• with circuit breaker	A	3.600	3.600	3.600	2.500
• with vacuum contactor	A	400 ²⁾	400 ²⁾	–	–
• with load break switch		as per fuse	as per fuse	as per fuse	as per fuse

¹⁾ Option: Higher values acc. to GOST standards

²⁾ Depending on the rated current of the HV HRC fuses installed

³⁾ 60 kV for vacuum contactor

Loss of service continuity category and partition class according to IEC	
Loss of service continuity	
• Category	LSC 2B
• Partition class	PM
Accessibility to compartments	
• Busbar compartment	Tool based
• Switching-device compartment	Interlock based
• Connection compartment	Interlock and tool based (front access) or tool based (rear access)

Internal arc classification according to IEC	
IAC	Internal arc classification
A	300 mm distance of indicators for test (installation in closed electrical service location)
F	Front arrangement of indicators for test
L	Lateral arrangement of indicators for test
R	Rear arrangement of indicators for test
I_{sc}	Test current for SIMOPRIME ≤ 17.5 kV up to 40 kA, ≤ 24 kV up to 25 kA
t	Arc duration 1 s, optionally 0.1 s

Definitions of the criteria
Criterion 1: Correctly secured doors and covers do not open. Limited deformations are accepted.
Criterion 2: No fragmentation of the enclosure. Projection of small parts up to an individual mass of 60 g are accepted.
Criterion 3: Arcing does not cause holes in the accessible sides up to a height of 2 m.
Criterion 4: Horizontal and vertical indicators do no ignite due to the effect of hot gases.
Criterion 5: The enclosure remains connected to its earthing point.

Type of service location

The switchgear can be used for indoor installation in accordance with IEC 61936 (power installations exceeding 1 kV AC) and VDE 0101

Inside lockable electrical service locations

A lockable electrical service location is a place outdoors or indoors that is reserved exclusively for housing electrical equipment and which is kept under lock and key. Access is restricted to authorized personnel and persons who have been properly instructed in electrical engineering. Untrained or unskilled persons may only enter under the supervision of authorized personnel or properly instructed persons.

Outside lockable electrical service locations

Outside lockable electrical service locations at places which are not accessible to the public. Enclosures of switchgear can only be removed with tools.

	IEC standard	VDE standard	DIN / EN standard	
SIMOPRIME switchgear	IEC 62271-1	VDE 0671-1	DIN / EN 62271-1	
	IEC 62271-200	VDE 0671-200	DIN / EN 62271-200	
Internal arcing tests	IEC 62271-200	VDE 0671-200	-	
Devices	Circuit breaker	IEC 62271-100	VDE 0671-100	DIN / EN 62271-100
	Vacuum contactor	IEC 60470	VDE 0670-501	DIN / EN 62271-106
	Disconnecter and earthing switch	IEC 62271-102	VDE 0671-102	DIN / EN 62271-102
	HV HRC fuses	IEC 60282	VDE 0670-4	DIN / EN 62271-103
	Voltage detecting systems	IEC 61243-5	VDE 0682-415	DIN / EN 62271-105
	Internal arc classification	IEC 62271-200	VDE 0671-200	DIN / EN 60282-1
Degree of protection	IEC 60529	VDE 0470-1	DIN / EN 61243-5	
	IEC 62271-200	VDE 0671-200	DIN / EN 60529	
Current-carrying capacity	IEC 62271-1	VDE 0671-1	DIN / EN 62271-1	
	IEC 62271-200 ¹⁾	VDE 0671-200 ¹⁾	DIN / EN 62271-200 ¹⁾	
Insulation	IEC 60071	VDE 0111	DIN / EN 61869-2	
Current transformer	IEC 61869-2	VDE 0414-1	DIN / EN 61869-3	
Voltage transformer	IEC 61869-3	VDE 0414-2	DIN / EN 61936-1	
Installation	IEC 62271	VDE 0101	-	
Enclosure	IP 4X ²⁾ (protection against solid foreign bodies)			
	Compartments: IP 2X (protection against solid foreign bodies)			

¹⁾ Ambient air temperatures: Maximum of 24 H mean + 35 °C | Maximum + 40 °C

- The current-carrying capacity of the panels and busbars depends on the ambient air temperature outside the enclosure.

- To attain the maximum rated normal currents, the panels are provided with natural or forced ventilation.

²⁾ Higher degree of protection IP 5x for enclosure on request.

Dielectric strength	kV	7.2	12	15	17.5	24
Rated short-duration power-frequency withstand voltage (rms value)						
Across isolating distances	kV	23	32	39	45	60
Between phases and to earth	kV	20	28	35	38	50
Rated lightning impulse withstand voltage (peak value)						
Across isolating distances	kV	70	85	105	110	145
Between phases and to earth	kV	60	75	95	95	125

Dielectric strength

The dielectric strength is verified by testing the switchgear with rated values of short-duration power-frequency withstand voltage and lightning impulse withstand voltage according to IEC 62271-1 / VDE 0671-1 (see table "Dielectric strength").

The rated values are referred to sea level and to normal atmospheric conditions (1013 hPa, 20 °C, 11 g/m³ humidity in accordance with IEC 60071 / VDE 0111).

The dielectric strength decreases with increasing altitude. For site altitudes above 1000 m (above sea level) the standards do not provide any guidelines for the insulation rating. Instead, special arrangements apply to these altitudes.

Site altitude:

- As the altitude increases, the dielectric strength in air decreases due to the decreasing air density. This reduction is permitted up to a site altitude of 1000 m according to IEC and VDE.
- For site altitudes above 1000 m, a higher insulation level must be selected. It results from the multiplication of the rated insulation level for 0 to 1000 m with the altitude correction factor K_a .

Altitude correction factor K_a

For site altitudes above 1,000 m, the altitude correction factor K_a is recommended, depending on the actual site altitude above sea level.

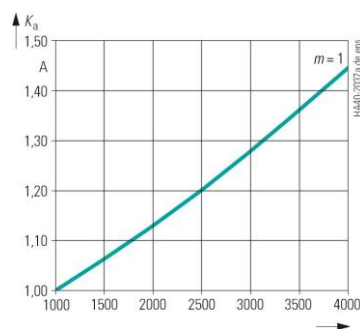

Rated short-duration power-frequency withstand voltage to be selected for site altitudes > 1,000 m
 \geq Rated short-duration power-frequency withstand voltage up to $\leq 1,000 \text{ m} \cdot K_a$

Rated lightning impulse withstand voltage to be selected for site altitudes > 1,000 m
 \geq Rated lightning impulse withstand voltage up to $\leq 1,000 \text{ m} \cdot K_a$

Example

1,800 m site altitude above sea level 12 kV switchgear rated voltage 75 kV rated lightning impulse withstand voltage
 Rated lightning impulse withstand voltage to be selected
 $75 \text{ kV} \times 1.10 = 82.5 \text{ kV}$

Result

According to the above table, a switchgear for a rated voltage of 17.5 kV is to be selected.

Climate and environmental influences

The switchgear may be used under the following environmental influences and climate classes:

Environmental influences

- Natural foreign materials ³⁾
- Chemically active pollutants ³⁾
- Small animals

Climate classes

- 3K3
- 3K5

The climate classes are classified according to IEC 60721-3-3.

³⁾ Depending on the size of foreign material or active pollutants additional measures may apply

Design

Basic panel design & operation - SIMOPRIME 17.5 kV

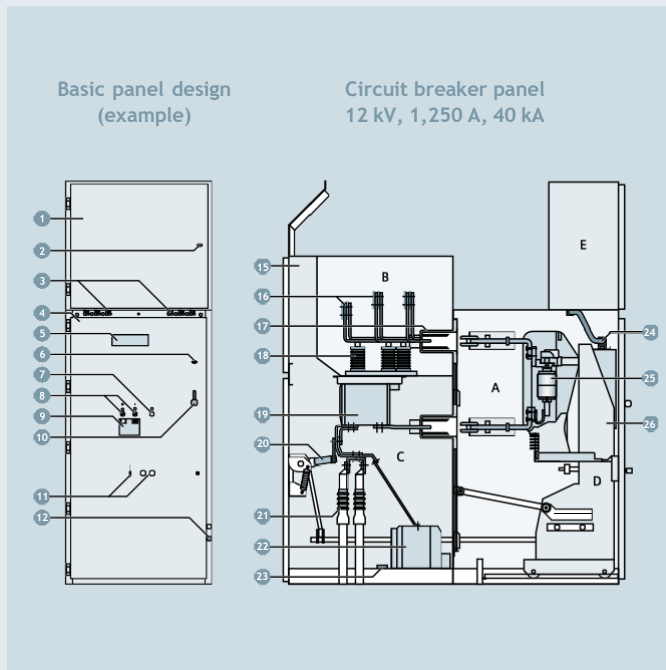

Legend for panel design

- 1 Door of low-voltage compartment
- 2 Opening for locking or unlocking the low-voltage compartment door
- 3 Option: Capacitive voltage detecting system for feeder and busbar
- 4 High-voltage door
- 5 Inspection window for checking the switching device truck
- 6 Opening for locking or unlocking the high-voltage door
- 7 Opening for mechanical charging of circuit breaker closing spring
- 8 Openings for manual operation (ON/OFF) of the circuit breaker
- 9 Inspection window for reading the indicators
- 10 Door handle
- 11 Openings for switching device truck operation
- 12 Opening for earthing-switch operation
- 13 Withdrawable VT operation opening lever
- 14 Withdrawable VT compartment door
- 15 Pressure relief duct
- 16 Busbars
- 17 Bushings
- 18 Post insulators
- 19 Block-type current transformer
- 20 Option: Make-proof earthing switch
- 21 Cable sealing ends
- 22 Option: Voltage transformer
- 23 Earthing busbar
- 24 Low-voltage plug connector
- 25 Vacuum interrupters
- 26 Switching device truck
- 27 Switching device withdrawable element
- 28 Withdrawable VT

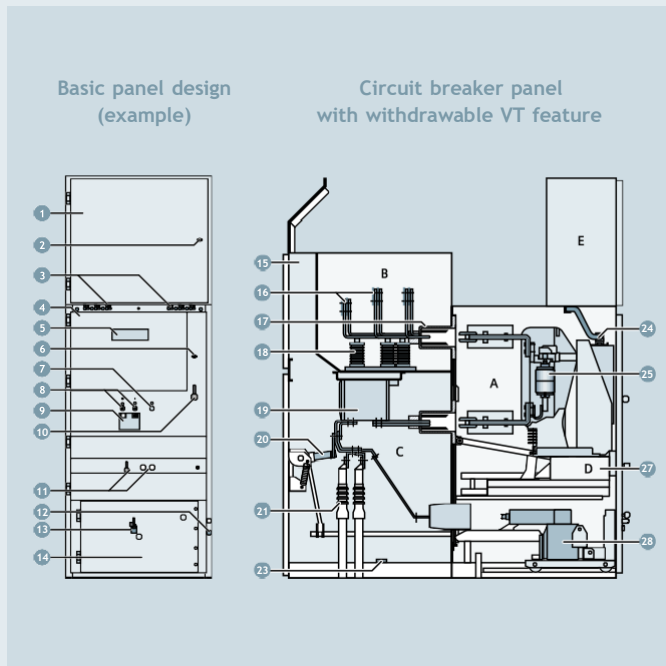

- A Switching device compartment
- B Busbar compartment
- C Connection compartment
- D Vacuum circuit breaker truck / withdrawable part
- E Low-voltage compartment

Compartments & features - SIMOPRIME 17.5 kV

Switching device compartment

- All switching operations with high-voltage door closed
- Pressure relief upwards
- Panel powder-coated with epoxy resin
- Shutter operating mechanisms separately for
 - Busbar compartment
 - Connection compartment
- Pressure resistant high voltage door in the event of internal arcs in the panel
- Metallic ducts on the side for laying control cables
- Interlocking between high-voltage door and circuit breaker truck ensures interlock based access
- Optional test:
 - Test sockets for capacitive voltage detecting system

Busbar compartment

- Pressure relief upwards and through rear pressure relief duct
- Busbars made of flat copper, bolted from panel to panel
- Bolted rear and top covers provide tool-based access
- Optional:
 - Coupling electrode for capacitive voltage detecting system
 - Insulated busbars
 - Busbar transverse partition between panels

Connection compartment

- Pressure relief upwards through rear pressure relief duct
- Suitable for connection of
 - Single-core XLPE cables up to max. 6 x 500 mm² per phase
 - Three-core XLPE cables up to max. 3 x 300 mm² per panel
 - Bars made of flat copper with bushings
- Earthing busbar
- Connection from front or rear
- Optional pressure:
 - Pressure-resistant floor cover
- Use of block-type current transformers
- Interlock and tool-based access for panels with connection from front
- Tool-based access for panels with connection from rear
- Coupling electrode for capacitive voltage detecting system
- Voltage transformers
 - Cast-resin insulated
 - Max. 3 x 1-pole
 - Fixed-mounted, without primary fuses
- Make-proof earthing switches with manual operating mechanism
- In addition to standard interlocking of earthing switch / circuit breaker truck, optionally lockable or with electromagnetic interlock
- Surge arresters or limiters
 - Surge arresters for protecting the switchgear against external overvoltages
 - Surge limiters for protecting consumers against switching overvoltages

Low-voltage compartment

- For accommodation of all protection, control, measuring and metering equipment
- Partitioned safe-to-touch from the high-voltage part
- Low-voltage compartment can be removed, bus wires and control cables are plugged in
- Optional partition:
 - Partition between panels

Voltage transformer compartment

- VT compartment to accommodate withdrawable voltage transformers
- VT compartment located under VCB in switching device compartment and has a separate door which has tool based access
- Voltage transformers
 - Cast-resin insulated
 - Max. 3 x 1-pole
 - Fixed-mounted on withdrawable part, with primary fuses

Interlocks

- Interlocking conditions are satisfied according to IEC 62271-200 / VDE 0671-200
- Earthing switch can only be operated with circuit breaker truck in test position. Circuit breaker truck can only be moved with circuit-breaker “OPEN” and earthing switch “OPEN”
- Coding on the LV-plug on circuit breaker. Prevents insertion of similar circuit breakers for lower rated currents into panels with higher rated currents
- Interlocking of high-voltage door against circuit breaker truck
- The high-voltage door can only be opened when the circuit breaker truck is in test position

Low-voltage cables

- Control cables of the panel are flexible and have metallic covers
- Bus wires are pluggable from panel to panel
- Connection of switching device truck and panel wiring to low-voltage compartment via 64-pole coded plug connectors

Technical Data

Dimensions - SIMOPRIME 17.5 kV

SIMOPRIME switchgear	up to 31.5 kA	up to 40 kA
Width in mm		
Circuit breaker panel		
≤1,250 A	600	800
2,500 A, 3,150 A, 3,600 A	800	800
Contactors panel	435/600	435
Disconnecting panel		
≤1,250 A	600	800
2,500 A, 3,150 A, 3,600 A	800	800
Bus sectionalizer / circuitbreaker panel		
≤1,250 A	600	800
2,500 A, 3,150 A, 3,600 A	800	800
Bus sectionalizer / bus riser panel		
≤1,250 A	600	800
2,500 A, 3,150 A, 3,600 A	800	800
Metering panel	600	800
Height in mm		
H1 With standard low-voltage compartment and IAC 0.1 s	2,253	2,253
H2 With standard low-voltage compartment and IAC 1.0 s	2,425	2,460
H3	1,780	1,780
Depth in mm		
D Standard	1,860	1,860

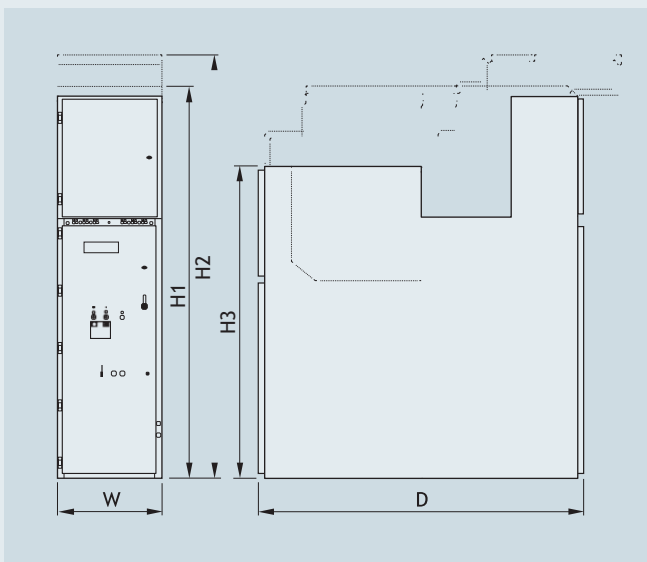

Classification according to IEC 62271-200		
Internal arc classification		
Classification	IAC	
Accessibility	Type A	
• Front	Type A	
• Rear	Type A	
• Lateral	Type A	
Test current	kA	25 / 31.5 / 40
Arc duration	s	0.1 / 1.0
Construction and design		
Partition class	PM (metallic partition)	
Loss of service continuity category	LSC2B (metal-clad)	
Compartment accessibility (standard)	Tool based	
• Busbar compartment	Interlock based	
• Switching device compartment	Interlock based	
• Low-voltage compartment	Interlock based	
• Connection compartment	Interlock and tool based	
- Front access	Tool based	
- Rear access	Tool based	

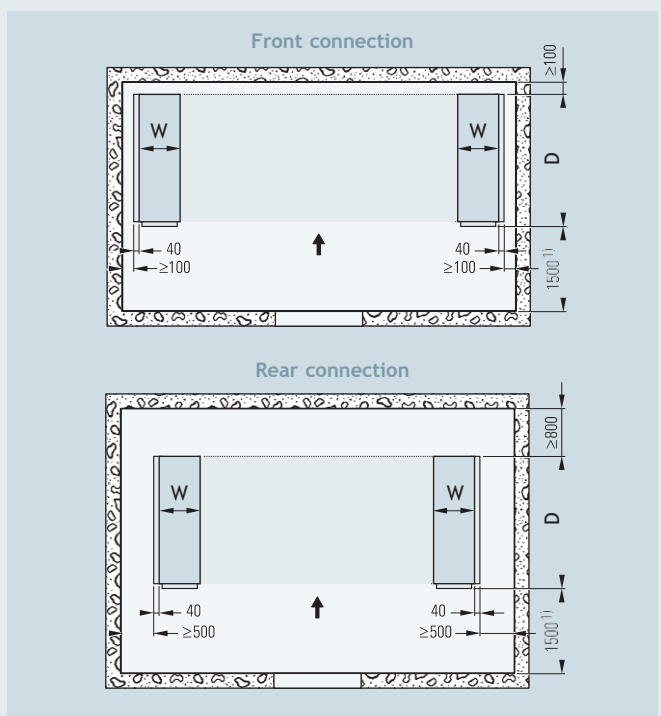

Pressure relief arrangement - SIMOPRIME 17.5 kV

Pressure relief				
Type of pressure relief	Rated voltage in kV	Ceiling height D in mm for short-circuit current ³⁾		
		25 kA	31.5 kA	40 kA
Pressure relief out of the switchgear room through a pressure relief channel	12.0 ¹⁾	≥ 2,800	≥ 2,800	
	17.5 ²⁾	≥ 2,800	≥ 2,800	≥ 2,800
Pressure relief into the switchgear room via flaps	≤ 17.5	≥ 2,800	≥ 2,800	≥ 2,800

¹⁾ with 600 mm panels, ²⁾ with 800 mm panels, ³⁾ in case of a lower than minimum ceiling height, please contact your SIMOPRIME partnering support

Pressure relief out of the switchgear room through a pressure relief duct

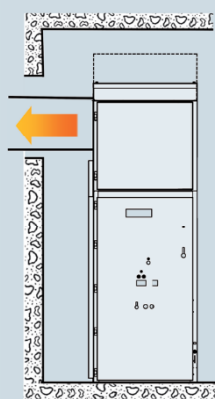

Lateral pressure relief duct

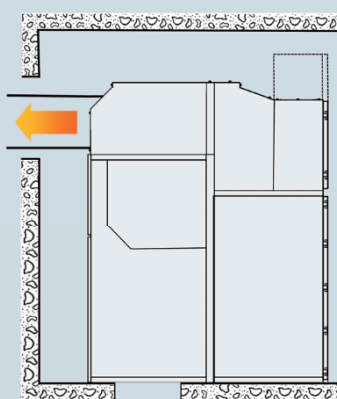

Rear pressure relief duct

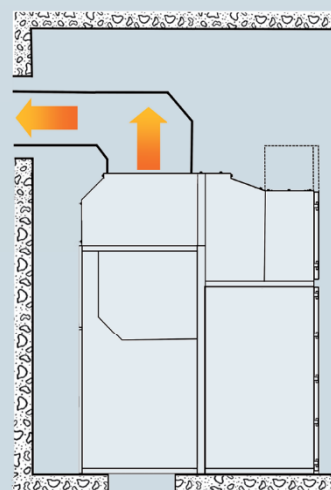

Upper pressure relief duct

Pressure relief into the switchgear room with/without flaps

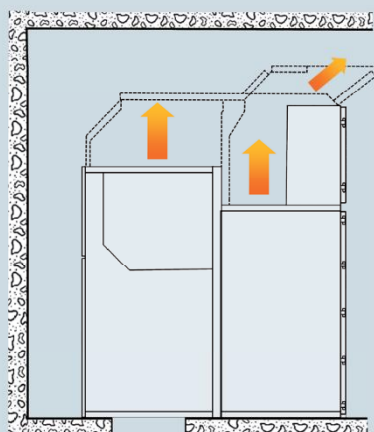
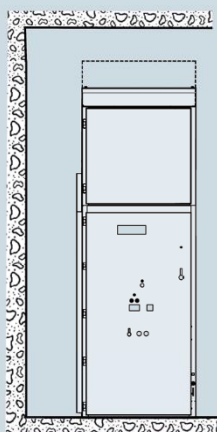

Pressure relief configuration	Arc duration in s
Lateral	1.0
Rear	1.0
Vertical	1.0
Flaps	1.0
No-flaps	0.1

For designs with a closed pressure relief duct to the outside, a distance of ≥ 500 mm is required on the side of exhaustion directed.

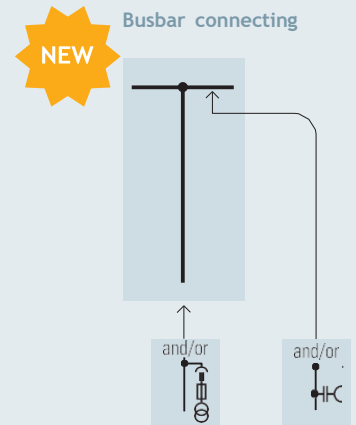
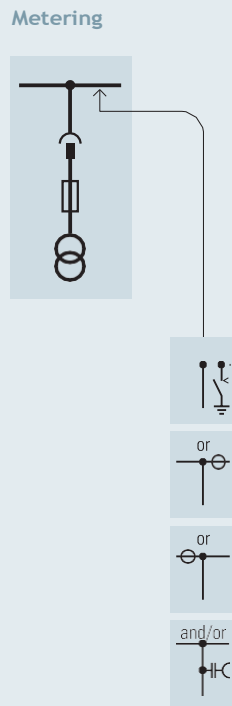
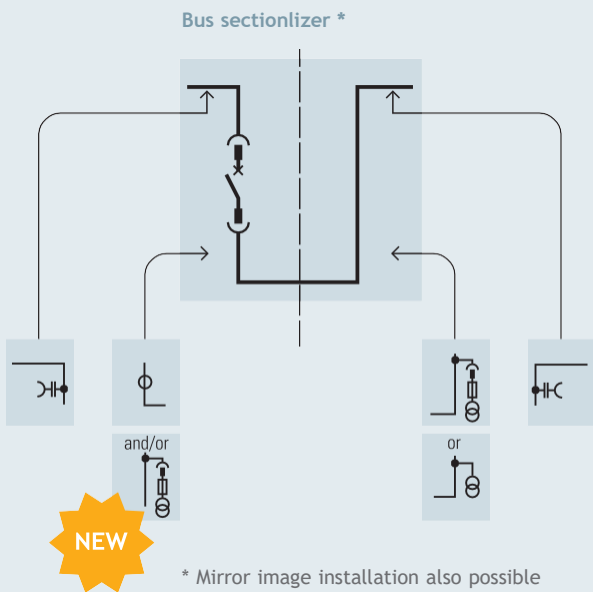

Legend					
ϕ	Current transformer		Vacuum contactor with HV HRC fuses		Vacuum circuit breaker
	Voltage transformer without primary fuses		Vacuum contactor with control transformer and HV HRC fuses		Disconnector
\ominus	Current transformer in run of busbar		Make-proof earthing switch		Withdrawable voltage transformer with primary fuses
HC	Capacitive voltage detecting system		Cable sealing ends max. 4 x 500 mm ² per phase		HV HRC fuses
	Voltage transformer with primary fuses		Bar connection		

Design

Basic panel design & operation - SIMOPRIME 24 kV

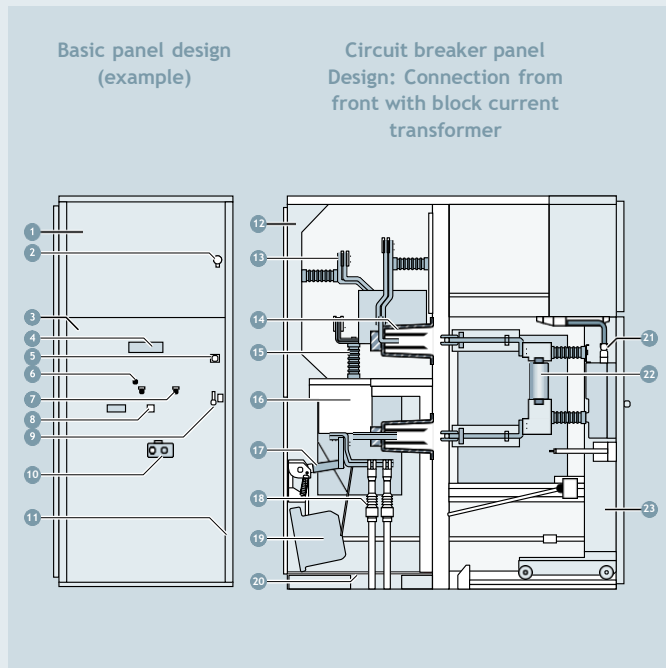

Legend for panel design

- 1 Door of low-voltage compartment
- 2 Opening for locking or unlocking the low-voltage compartment door
- 3 High-voltage door
- 4 Inspection window for checking the switching device truck
- 5 Opening for locking or unlocking the high-voltage door
- 6 Opening for mechanical charging of circuit breaker closing spring
- 7 Openings for manual operation (ON/OFF) of the circuit breaker
- 8 Inspection window for reading the indicators
- 9 Door handle
- 10 Openings for switching device truck operation
- 11 Opening for earthing-switch operation
- 12 Pressure relief duct
- 13 Busbars
- 14 Bushings
- 15 Post insulators
- 16 Block-type current transformer
- 17 Option: Make-proof earthing switch
- 18 Cable sealing ends
- 19 Option: Voltage transformer
- 20 Earthing busbar
- 21 Low-voltage plug connector
- 22 Vacuum interrupters
- 23 Switching device truck

- A Switching device compartment
- B Busbar compartment
- C Connection compartment
- D Vacuum circuit breaker truck
- E Low-voltage compartment

Compartments & features - SIMOPRIME 24 kV

Switching device compartment

- All switching operations with high-voltage door closed
- Pressure relief upwards
- Panel powder-coated with epoxy resin
- Shutter operating mechanisms separately for
 - Busbar compartment
 - Connection compartment
- Metallic, earthed shutters and partitions ensure partition class PM
- High-voltage door pressure resistant in the event of internal arcs in the panel
- Metallic ducts on the side for laying control cables
- Interlocking between high-voltage door and circuit breaker truck ensures interlock based access

Busbar compartment

- Pressure relief upwards and through rear pressure relief duct
- Busbars made of flat copper, bolted from panel to panel
- For rated normal currents up to 2,500 A
- Bolted top covers provide tool-based access
- Optional:
 - Coupling electrode for capacitive voltage detecting system
 - Insulated busbars
 - Busbar transverse partition between panels

Connection compartment

- Pressure relief upwards through rear pressure relief duct
- Suitable for connection of
 - Single-core XLPE cables up to max. 4 x 500 mm² per phase
 - Three-core XLPE cables up to max. 3 x 300 mm² per panel
- Shutters to be opened separately to permit cable testing
- Earthing busbar
- Connection from front or rear
- Use of block-type current transformers
- Bolted rear covers of the connection compartment provide tool-based access for panels with connection from rear
- Interlocked high-voltage door and bolted partitions between connection compartment and switching device compartment provide interlock and tool based access for panels with connection from front
- Optional:
 - Coupling electrode for capacitive voltage detecting system
 - Voltage transformers
 - Cast-resin insulated
 - Max. 3 x 1-pole
 - Fixed-mounted, without primary fuses
 - Make-proof earthing switches
 - With manual operating mechanism
 - In addition to standard interlocking of earthing switch/circuit breaker truck, optionally lockable or with electromagnetic interlock
 - Surge arresters
 - Surge arresters for protecting the switchgear against external overvoltages

Low-voltage compartment

- For accommodation of all protection, control, measuring and metering equipment
- Partitioned safe-to-touch from the high-voltage part
- Low-voltage compartment can be removed, bus wires and control cables are plugged in

Interlocks

- Interlocking conditions are satisfied according to IEC 62271-200 / VDE 0671-200
- Earthing switch can only be operated with circuit breaker truck in test position
- Circuit breaker truck can only be moved with circuit breaker “OPEN” and earthing switch “OPEN”
- Mechanical coding on the circuit breaker truck prevents insertion of similar circuitbreaker trucks for lower rated normal currents into panels with higher rated normal currents
- Interlocking of high-voltage door against circuit breaker truck
- The high-voltage door can only be opened when the circuit breaker truck is in test position
- Optional:
 - Electromagnetic interlocks

Technical Data

Dimensions - SIMOPRIME 24 kV

SIMOPRIME switchgear	25 kA
Width in mm	
Circuit-breaker panel	
for 1,250 A	800
for 2,500 A	1,000
Load break switch	500
Height in mm	
H1 With standard low-voltage compartment and IAC 0.1 s	2,250
H2 With additional pressure relief channel for IAC 1.0 s	2,728
Depth in mm	
D Standard	1,900

Classification according to IEC 62271-200	
Construction and design	
Partition class	PM (metallic partition)
Loss of service continuity category	LSC2B (metal-clad)
Compartment accessibility (standard)	Tool based Interlock based Interlock based Interlock and tool based Tool based
<ul style="list-style-type: none"> • Busbar compartment • Switching-device compartment 	
<ul style="list-style-type: none"> • Low-voltage compartment • Connection compartment 	
<ul style="list-style-type: none"> - Front access - Rear access 	

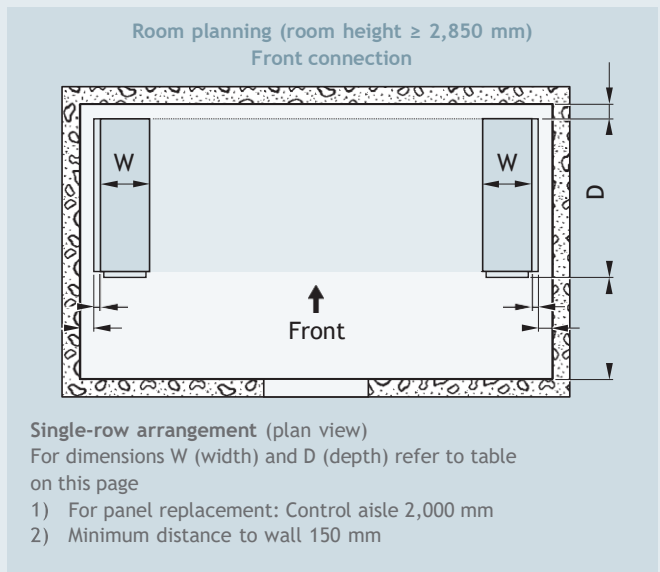
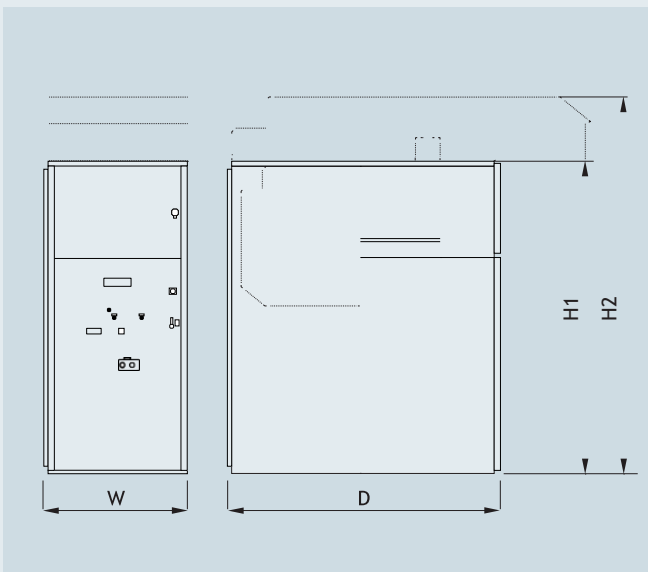

Product range

Panels - SIMOPRIME 24 kV

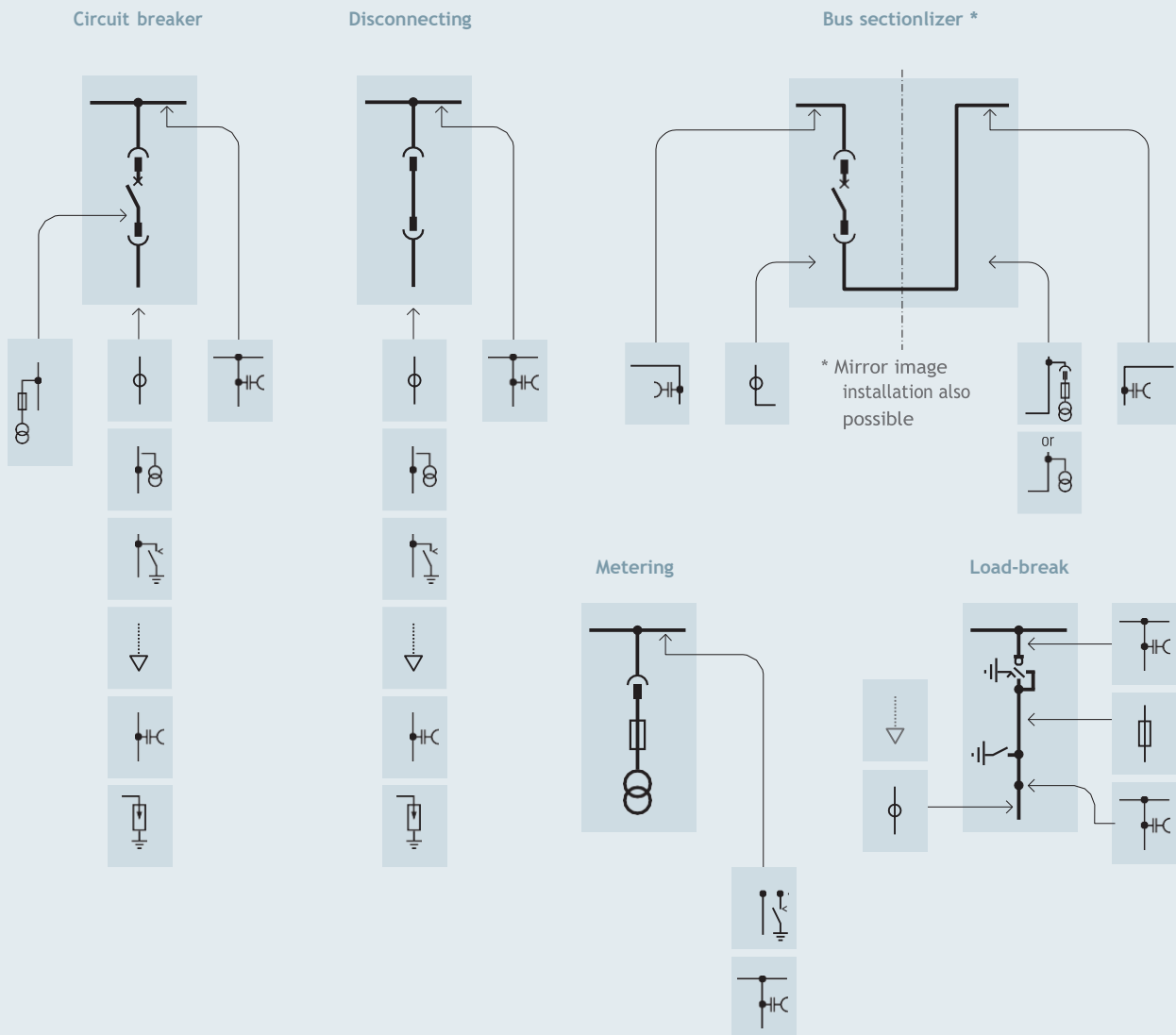

Legend					
	Current transformer		Withdrawable voltage transformer with primary fuses		HV HRC fuses
	Voltage transformer without primary fuses		Make-proof earthing switch		3AH5 vacuum circuit breaker
	Voltage transformer with primary fuses		Disconnecting link or dummy truck		Three-position switch-disconnector
	Capacitive voltage detecting system		Cable sealing ends ¹⁾ max. 4 x 500 mm ² per phase		Surge arrester

¹⁾ The details refer to conventional RXS single-core sealing ends for XLPE cables or other makes with similar dimensions.

SIMOPRIME SDC

SDC - Switching device compartment



Product features

SIMOPRIME SDC is a type-tested stand-alone product.

SIMOPRIME SDC has all the feature and customization options as the SIMOPRIME switchgear

- Safe operation with interlocks
- Fully type-tested according to IEC 62271-200
- PM class full metal enclosure with metallic shutters
- Wide range of technical support
- Compatibility with wide range of SIEMENS medium-voltage components

With SIMOPRIME SDC, panel builders can design their cable and busbar compartments to meet specific technical requirements.

This product is almost like an off-the-shelf product orderable with article number through electronic catalog.

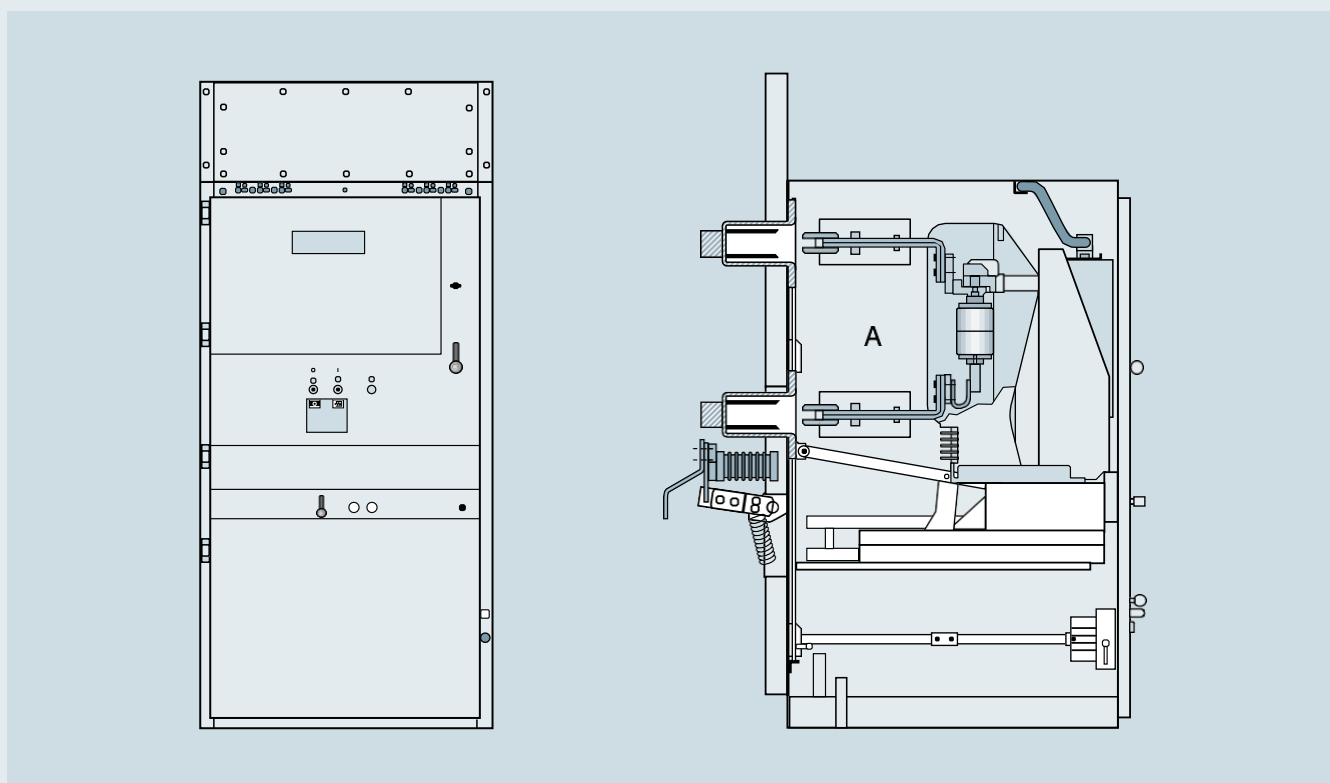

SIMOPRIME SDC switchgear up to		7.2 kV	12 kV	17.5 kV
Rated voltage	kV	7.2	12	17.5
Rated frequency	Hz	50/60	50/60	50/60
Rated short-duration power-frequency withstand voltage	kV	20	28	38
Rated lightning impulse withstand voltage	kV	60	75	95
Rated short-time withstand current in 3s	kA	40	40	40
Rated peak withstand current at 50/60 Hz	kA	100/104	100/104	100/104
Rated short-circuit breaking current	kA	40	40	40
Rated short-circuit making current at 50/60 Hz	kA	100/104	100/104	100/104
Rated normal current of busbar	A	3,600	3,600	3,600